

SHIRE OF COLLIE**List of Accounts Submitted to Council - December 2019**

Chq/EFT	Date	Name	Description	Amount	Bank	Type
DEC19	03/12/2019	SC1 - SCOPE-ADMIN COLOUR COPIER (\$566.50)	SCOPE-ADMIN COLOUR COPIER (\$566.50)	-	566.50	BENMUNI FEE
DEC19	19/12/2019	KM1 - KONICA-DEPOT COPIER LEASE (\$115.50)	KONICA-DEPOT COPIER LEASE (\$115.50)	-	115.50	BENMUNI FEE
DEC19	16/12/2019	KM2 - ROCHE PARK PHOTOCOPIER (\$115.50)	ROCHE PARK PHOTOCOPIER (\$115.50)	-	115.50	BENMUNI FEE
DEC19	24/12/2019	AP1 - AUSTRALIA POST	AUSTRALIA POST	-	594.50	BENMUNI FEE
DEC19	24/12/2019	WM2 - CAPITAL FINANCE-LIBRARY COPIER (\$231.00)	CAPITAL FINANCE-LIBRARY COPIER (\$231.00)	-	231.00	BENMUNI FEE
DEC19	19/12/2019	FF1 - FINES ENFORCEMENT FEES	FINES ENFORCEMENT FEES	-	140.00	BENMUNI FEE
DEC19	31/12/2019	BF1 - BANK FEES	AUSTRALIA POST	-	2,181.17	BENMUNI FEE
EFT27745	05/12/2019	Water Corporation	Water Account 90 06814 96 2 Swimming Pool Usage and Service Charges 01/11/2019 to 31/12/2019	-	16,334.27	BENMUNI CSH
0163	19/11/2019	Water Corporation	Water Account 90 06817 34 6 Caretakers Cottage Rec Grounds Usage and Service Charges 01/11/2019 to 31/12/2019 ,		274.92	BENMUNI INV
0159	20/11/2019	Water Corporation	Water Account 9006813302 Hall At 59 Wittenoom St Usage And Service Charges 01/11/2019 To 31/12/2019		65.84	BENMUNI INV
0112	20/11/2019	Water Corporation	Water Account 9006846155 Hebe Park At Wellington Boulevard Usage and Service Charge 01/11/2019 to 31/12/2019,		2,194.47	BENMUNI INV
0154	20/11/2019	Water Corporation	Water Account 9006815340 Throssell St Toilets Usage And Service Charges 01/11/2019 To 31/12/2019		595.60	BENMUNI INV
0118	20/11/2019	Water Corporation	Water Account 9006815439 Finlay Park At Throssell St Usage And Service Charges 01/11/2019 To 31/12/2019		2,864.49	BENMUNI INV
0067	20/11/2019	Water Corporation	Water Account 9006847342 Cemetery Usage And Service Charges 01/11/2019 To 31/12/2019		296.06	BENMUNI INV
0140	20/11/2019	Water Corporation	Water Account 9006815332 RSL Hall Usage And Service Charges 01/11/2019 To 31/12/2019		232.68	BENMUNI INV

SHIRE OF COLLIE**List of Accounts Submitted to Council - December 2019**

Chq/EFT	Date	Name	Description	Amount	Bank	Type
0155	20/11/2019	Water Corporation	Water Account 9006815391 Railway Hall Throssell Street Usage and Service Charge 01/11/2019 to 31/12/2019,	126.40	BENMUNI	INV
0155	20/11/2019	Water Corporation	Water Account 9006815463 Tourist Centre at 156 Throssell Street CollieLot 2884 Res Usage and Service charges 01/11/2019 to 31/12/2019 ,	785.84	BENMUNI	INV
0158	21/11/2019	Water Corporation	Water Account 90 06813 93 5 Library 20 Steere Street Usage and Service Charge 01/11/2019 to 31/12/2019 ,	600.82	BENMUNI	INV
0159	21/11/2019	Water Corporation	Water Account 90 06814 96 2 Swimming Pool Usage and Service Charges 01/11/2019 to 31/12/2019 ,	4,234.63	BENMUNI	INV
0124	21/11/2019	Water Corporation	Water Account 90 06815 08 4, Throssell Street Park, Usage and Service Charges 01/11/2019 to 31/12/2019 ,	67.52	BENMUNI	INV
0160	21/11/2019	Water Corporation	Water Account 90 06813 92 7 Collie Community Radio Building Usage and Service Charges 01/11/2019 to 31/12/2019 ,	395.66	BENMUNI	INV
0163	21/11/2019	Water Corporation	Water Account 90 06814 57 5 Museum 161 Throssell Street Usage and Service Charges 01/11/2019 to 30/12/2019 ,	58.72	BENMUNI	INV
0163	21/11/2019	Water Corporation	Water Account 90 06814 95 4 87 Throssell Street Usage and Service Charges 01/11/2019 to 30/12/2019 ,	919.51	BENMUNI	INV
0157	25/11/2019	Water Corporation	WATER ACCOUNT 9006828272 BMX CLUB USAGE and SERVICE CHARGES 01/11/2019 to 31/12/2019 ,	313.84	BENMUNI	INV
0030	25/11/2019	Water Corporation	Water Account 90 21019 40 6 26 Morrison Way - Depot Usage and Service Charge 01/11/2019 to 31/12/2019 ,	378.64	BENMUNI	INV
0122	25/11/2019	Water Corporation	Water Account 9006838606 Hall At Palmer Rd Usage And Service Charges 01/11/2019 to 31/12/2019	101.29	BENMUNI	INV

SHIRE OF COLLIE**List of Accounts Submitted to Council - December 2019**

Chq/EFT	Date	Name	Description	Amount	Bank	Type
0126	27/11/2019	Water Corporation	Water Account 9006825004 Roche Park Sports Ground Usage And Service Charges 01/11/19 to 31/12/19	301.25	BENMUNI	INV
0102	27/11/2019	Water Corporation	Water Account 90 08719 47 5 Waste Transfer Station Usage and Service Charges 01/11/2019 to 31/12/2019 ,	62.33	BENMUNI	INV
0168	27/11/2019	Water Corporation	Water Account 9006824992 Roche Park Indoor Sports Usage And Service Charges 01/11/2019 To 31/12/2019	478.45	BENMUNI	INV
0160	29/11/2019	Water Corporation	Water Account 9006810515 Lions Park Usage To 22/05/2019 Service Charges 01/11/2019 To 31/12/2019	121.66	BENMUNI	INV
0168	29/11/2019	Water Corporation	Water Account 90 06823 79 7 Wallsend Showgrounds Usage and Service Charge 01/11/2019 to 31/12/2019 ,	863.65	BENMUNI	INV
EFT27746	05/12/2019	Synergy	Electricity Account 221 101 470 Truck Bay 21/09/2019 to 21/11/2019	-	518.00	BENMUNI CSH
2012802840	01/11/2019	Synergy	ELECTRICITY ACCOUNT 428265630 DECORATIVE LIGHTS 02/10/19 to 01/11/19,	46.19	BENMUNI	INV
2088824119	25/11/2019	Synergy	Electricity Account 221 101 470 Truck Bay 21/09/2019 to 21/11/2019 ,	471.81	BENMUNI	INV
EFT27747	06/12/2019	Lindaz Central Deli	Milk Purchased for Admin July 2019	-	619.20	BENMUNI CSH
00000368	11/07/2019	Lindaz Central Deli	Milk Purchased for Admin July 2019,	172.80	BENMUNI	INV
00000374	21/08/2019	Lindaz Central Deli	Milk Purchased for Admin August 2019	158.40	BENMUNI	INV
00000377	03/10/2019	Lindaz Central Deli	Milk Purchased for Admin September	158.40	BENMUNI	INV
00000379	29/10/2019	Lindaz Central Deli	Milk Purchased for Admin October 2019,	129.60	BENMUNI	INV
EFT27748	06/12/2019	Arrow Bronze	Single Niche wall plaque C143mm x 177mm (Flat Back) for Terence Partridge	-	241.28	BENMUNI CSH
687849	20/11/2019	Arrow Bronze	Single Niche wall plaque C143mm x 177mm (Flat Back) for Terence Partridge	241.28	BENMUNI	INV
EFT27749	06/12/2019	Air Liquide WA Pty Ltd	Delivery of Cylinder Ozygen and Acetylene	-	237.60	BENMUNI CSH

SHIRE OF COLLIE**List of Accounts Submitted to Council - December 2019**

Chq/EFT	Date	Name	Description	Amount	Bank	Type
GM9179	19/11/2019	Air Liquide WA Pty Ltd	Exchange cylinder Oxygen Ind E for workshop, Exchange cylinder Acetylene Ind E for workshop, Exchange cylinder Acetylene Ind G for handyman, Exchange cylinder Oxygen Ind G for handyman, Delivery of Cylinder Ozygen and Acetylene	237.60	BENMUNI	INV
EFT27750	06/12/2019	AMD Audit & Assurance Pty Ltd	Audit of the Financial Statements for the Year Ended 30 June 2019	-	8,470.00	BENMUNI CSH
801682	19/11/2019	AMD Audit & Assurance Pty Ltd	Audit of the Financial Statements for the Year Ended 30 June 2019	-	8,470.00	BENMUNI INV
EFT27751	06/12/2019	Auto1 Collie	Pro Gear Oil (Go8090020) for Mechanic workshop stock	-	316.16	BENMUNI CSH
383211	05/04/2019	Auto1 Collie	Gear Oil Premium 80w90 (Go80900025), Penrite Gear Oil (Go8090004), Pro Gear Oil (Go8090020) for Mechanic workshop stock	-	316.16	BENMUNI INV
EFT27752	06/12/2019	Agrizzi Farm Machinery	Kubota L4240 HDCA Tractor (CO30016) - 4 x blades, 8 x bolts,nuts,washers, 2 x beams	-	728.00	BENMUNI CSH
00018656	18/11/2019	Agrizzi Farm Machinery	Kubota L4240 HDCA Tractor (CO30016) - 4 x blades, 8 x bolts,nuts,washers, 2 x beams	-	728.00	BENMUNI INV
EFT27753	06/12/2019	ADELPHI APPARELL	2 x ranger work shirts	-	187.00	BENMUNI CSH
00050259	15/11/2019	ADELPHI APPARELL	2 x ranger work shirts	-	187.00	BENMUNI INV
EFT27754	06/12/2019	A & B CANVAS AUSTRALIA	SES Tarp 9.15m x 6m with SES Logo (Yellow) DFES - LGGS Approved Capital Grant - Line 9 Item	-	5,709.00	BENMUNI CSH
30750	13/11/2019	A & B CANVAS AUSTRALIA	SES Tarp 3.6m x 3.6m with SES Logo (Yellow), DFES - LGGS Approved Capital Grant - Line 9 Item, SES Tarp 9.15m x 6m with SES Logo (Yellow), DFES - LGGS Approved Capital Grant - Line 9 Item	-	5,709.00	BENMUNI INV
EFT27755	06/12/2019	AMALGAMATED CIVIL & PLANT HIRE PTY LTD	Supply gravel for the river walk Lions Park.	-	9,440.00	BENMUNI CSH
00000053	21/11/2019	AMALGAMATED CIVIL & PLANT HIRE PTY LTD	Supply gravel for the river walk Lions Park.	-	9,000.00	BENMUNI INV
00000060	21/11/2019	AMALGAMATED CIVIL & PLANT HIRE PTY LTD	Day hire of Positrack for use on River Walk construction Stage 3 Lions Park	-	220.00	BENMUNI INV

SHIRE OF COLLIE

List of Accounts Submitted to Council - December 2019

Chq/EFT	Date	Name	Description	Amount	Bank	Type
00000059	21/11/2019	AMALGAMATED CIVIL & PLANT HIRE PTY LTD	Day hire of positrack bobcat for removal of footpath on River Walk construction	220.00	BENMUNI	INV
EFT27756	06/12/2019	Ampac Debt Recovery (WA) Pty Ltd	Ampac Debt Recovery for Rates Period Ending 15/11/2019 -	16.50	BENMUNI	CSH
61148	21/11/2019	Ampac Debt Recovery (WA) Pty Ltd	Ampac Debt Recovery for Rates Period Ending 15/11/2019	16.50	BENMUNI	INV
EFT27757	06/12/2019	Allanson Bushfire Brigade	Station Supplies -	252.49	BENMUNI	CSH
PETTY CASH AUGUST/SEPTEMBER	29/09/2019	Allanson Bushfire Brigade	Mop for Station, Bread Rolls for Brigade Training BBQ, Internet Data for Station WIFI, Food for Brigade Training, Meat for Brigade Training BBQ, Station Supplies, Burn Dinner for Brigade	252.49	BENMUNI	INV
EFT27758	06/12/2019	AFGRI Equipment Australia PTY LTD	Travel to site to check fan noise issue on John Deere 670GP Motor Grader (CO17002) -	3,680.86	BENMUNI	CSH
1878470	30/10/2019	AFGRI Equipment Australia PTY LTD	Travel to site to check fan noise issue on John Deere 670GP Motor Grader (CO17002)	3,680.86	BENMUNI	INV
EFT27759	06/12/2019	A & R MACHINERY	Kubota Tractor Aust (85HP Cab Tractor) M8540DHC - engine oil filters HH16432430 -	34.65	BENMUNI	CSH
00001122	11/11/2019	A & R MACHINERY	Kubota Tractor Aust (85HP Cab Tractor) M8540DHC - engine oil filters HH16432430	34.65	BENMUNI	INV
EFT27760	06/12/2019	Armac Stump Grinding	Remove 3 x dead trees on Beela Rd as directed, chip smaller branches and remove mulch, leave big log on site, no stump grinding. -	5,620.00	BENMUNI	CSH
00002697	14/11/2019	Armac Stump Grinding	Stump grinding 07/11 as instructed by Parks & Gardens supervisor	2,420.00	BENMUNI	INV
00002709	14/11/2019	Armac Stump Grinding	Remove 3 x dead trees on Beela Rd as directed, chip smaller branches and remove mulch, leave big log on site, no stump grinding.	3,200.00	BENMUNI	INV
EFT27761	06/12/2019	AusQ Training	Basic worksafe traffic management and traffic controller reaccreditation Wed 13th November reaccrediation training. -	1,654.00	BENMUNI	CSH
4595	12/11/2019	AusQ Training	Basic worksafe traffic management and traffic controller reaccreditation Wed 13th November reaccrediation training.	1,098.00	BENMUNI	INV

SHIRE OF COLLIE**List of Accounts Submitted to Council - December 2019**

Chq/EFT	Date	Name	Description	Amount	Bank	Type
4611	18/11/2019	AusQ Training	Main Roads WA Advanced Worksite Traffic Management (AWTM) accreditation	556.00	BENMUNI	INV
EFT27762	06/12/2019	Collie Boulevard Cafe	Catering for Seniors Week Event	-	1,085.00	BENMUNI CSH
00000397	30/10/2019	Collie Boulevard Cafe	Employee of month		115.00	BENMUNI INV
00000401	12/11/2019	Collie Boulevard Cafe	Council Meeting Meal - Tuesday 12 November 2019 to be delivered Council Chambers via the back door at 8.00pm.		250.00	BENMUNI INV
00000402	13/11/2019	Collie Boulevard Cafe	Morning Tea farewell for Employee # 584		100.00	BENMUNI INV
00000404	15/11/2019	Collie Boulevard Cafe	Catering for Seniors Week Event		198.00	BENMUNI INV
00000403	15/11/2019	Collie Boulevard Cafe	Catering for Seniors Week Event		422.00	BENMUNI INV
EFT27763	06/12/2019	BELL FIRE EQUIPMENT	2 x Mask Bags for Pool BA Sets 2 x Cylinders Re Fill for BA Sets	-	198.00	BENMUNI CSH
INV-2345	21/11/2019	BELL FIRE EQUIPMENT	2 x Mask Bags for Pool BA Sets, 2 x Cylinders Re Fill for BA Sets		198.00	BENMUNI INV
EFT27764	06/12/2019	Bags O' Rags	Bags Of Rags for stock	-	57.20	BENMUNI CSH
09128	14/11/2019	Bags O' Rags	Bags Of Rags for stock		57.20	BENMUNI INV
EFT27765	06/12/2019	Blue East PTY LTD	Supply gravel for the Shannon Road construction	-	7,781.40	BENMUNI CSH
0042	15/11/2019	Blue East PTY LTD	Supply gravel for the Shannon Road construction		4,022.13	BENMUNI INV
0043	15/11/2019	Blue East PTY LTD	Supply gravel for the Cardiff Fire Station access.		3,759.27	BENMUNI INV
EFT27766	06/12/2019	Collie Freightlines	Freight Deliveries to Depot October 2019	-	658.35	BENMUNI CSH
00002565	31/10/2019	Collie Freightlines	Freight Deliveries to Depot October 2019 , , Freight Deliveries to Admin October 2019 ,		658.35	BENMUNI INV
EFT27767	06/12/2019	Collie Auto Electrics	Diagnose and repair air con fault and supply parts for 2007 Bobcat S185H Skid Steere Loader (CO18857)	-	500.00	BENMUNI CSH
00006737	21/11/2019	Collie Auto Electrics	Diagnose and repair air con fault and supply parts for 2007 Bobcat S185H Skid Steere Loader (CO18857)		500.00	BENMUNI INV
EFT27768	06/12/2019	Statewide Bearings	20m x 8mm poly hose for reticulation installation at Lions Park River Walk	-	195.80	BENMUNI CSH
2491378	15/11/2019	Statewide Bearings	Cans of Lanox for workshop stock		48.40	BENMUNI INV

SHIRE OF COLLIE**List of Accounts Submitted to Council - December 2019**

Chq/EFT	Date	Name	Description	Amount	Bank	Type
INV2491406	19/11/2019	Statewide Bearings	20m x 8mm poly hose for reticulation installation at Lions Park River Walk, Joiners for reticulation	102.30	BENMUNI	INV
2491408	19/11/2019	Statewide Bearings	Grease fitting for 2011 Caterpillar 924H Loader (1DQY895)	23.10	BENMUNI	INV
2491460	22/11/2019	Statewide Bearings	2 x Wheel bearings for replacement on Peruzzo.	22.00	BENMUNI	INV
EFT27769	06/12/2019	Collie Salvage & Hardware	Sheets of F62 mesh	-	285.60	BENMUNI CSH
8946	16/10/2019	Collie Salvage & Hardware	Roll of masking plastic film for Cardiff Fire Station pad and path, Roll of masking plastic film with dispenser, Rolls of 36mm masking tape, Sheets of F62 mesh	285.60	BENMUNI	INV
EFT27770	06/12/2019	Collie Senior Citizens Inc	Reimbursement Of Water Charges At Margaretta Wilson Centre Usage To 01/07/2019 And Service Charges 01/09/19 - to 31/10/19	865.08	BENMUNI	CSH
04122019	04/12/2019	Collie Senior Citizens Inc	Reimbursement Of Water Charges At Margaretta Wilson Centre Usage To 01/07/2019 And Service Charges 01/07/19 to 31/08/19, Reimbursement Of Water Charges At Margaretta Wilson Centre Usage To 01/07/2019 And Service Charges 01/09/19 to 31/10/19	865.08	BENMUNI	INV
EFT27771	06/12/2019	Collie Electrical Service	Disconnection of power to enable water meter/pipe repairs at Wallsend Ground, reconnection	-	165.00	BENMUNI CSH
00010274	16/11/2019	Collie Electrical Service	Disconnection of power to enable water meter/pipe repairs at Wallsend Ground, reconnection	165.00	BENMUNI	INV
EFT27772	06/12/2019	COLLIE BUS SERVICE	Bus Service for Seniors Week event	-	154.00	BENMUNI CSH
1246	19/11/2019	COLLIE BUS SERVICE	Bus Service for Seniors Week event	154.00	BENMUNI	INV
EFT27774	06/12/2019	Schweppes Australia Pty Ltd	Roche Park Drinks Order - 3 x 600ml water 2 x Grape gatorade 1 x Watermelon gatorade	-	165.41	BENMUNI CSH
0809176519	14/11/2019	Schweppes Australia Pty Ltd	Roche Park Drinks Order - , 3 x 600ml water, 2 x Grape gatorade, 1 x Watermelon gatorade	165.41	BENMUNI	INV

SHIRE OF COLLIE**List of Accounts Submitted to Council - December 2019**

Chq/EFT	Date	Name	Description	Amount	Bank	Type
EFT27775	06/12/2019	Crank'n Cycles	SPOTY Awards engraving of trophies and medals	- 80.00	BENMUNI	CSH
TR19092301	22/11/2019	Crank'n Cycles	SPOTY Awards engraving of trophies and medals	80.00	BENMUNI	INV
EFT27776	06/12/2019	Comfortstyle Collie	2 x accent reading chairs for library	- 698.00	BENMUNI	CSH
3966	09/09/2019	Comfortstyle Collie	2 x accent reading chairs for library	698.00	BENMUNI	INV
EFT27777	06/12/2019	Collie Senior High School	Donation - Presentation Top Year 8 Shire Award 2019	- 200.00	BENMUNI	CSH
7365	12/11/2019	Collie Senior High School	Donation - Presentation Top Year 8 Shire Award 2019	200.00	BENMUNI	INV
EFT27778	06/12/2019	Drycleaners On Steere	Maintenance of Council Chambers - Drycleaning - October to December 2019	- 16.50	BENMUNI	CSH
7923	12/11/2019	Drycleaners On Steere	Maintenance of Council Chambers - Drycleaning - October to December 2019	16.50	BENMUNI	INV
EFT27779	06/12/2019	Coates Hire	Hire 5T mini excavator for grave excavation 08/11 - shire backhoe under repair	- 446.46	BENMUNI	CSH
18856654	13/11/2019	Coates Hire	Hire 5T mini excavator for grave excavation 08/11 - shire backhoe under repair, Hire 5T mini excavator for River Walk Stage 3 construction - shire backhoe under repair	446.46	BENMUNI	INV
EFT27780	06/12/2019	Craven Foods	Roche Park - Confectionery, wooden forks	- 361.95	BENMUNI	CSH
4617013	14/11/2019	Craven Foods	Roche Park - Tissues, Roche Park - Confectionery, wooden forks	228.36	BENMUNI	INV
4617927	20/11/2019	Craven Foods	Roche Park Kiosk - Confectionery, Corn chips	133.59	BENMUNI	INV
EFT27781	06/12/2019	CONNECTIV SOUTH	2 Lifeproof Phone Cases for State Emergency Services	- 267.00	BENMUNI	CSH
60154176	08/11/2019	CONNECTIV SOUTH	2 Lifeproof Phone Cases for State Emergency Services	267.00	BENMUNI	INV
EFT27782	06/12/2019	Daves Cleaning Service	Cleaning of public toilets and BBQ's for 19/20 financial year.	- 6,421.10	BENMUNI	CSH
51	01/12/2019	Daves Cleaning Service	Cleaning of public toilets and BBQ's for 19/20 financial year.	6,421.10	BENMUNI	INV
EFT27783	06/12/2019	Landgate	Annual Subscription for SLIP Services 2019-20	- 2,318.00	BENMUNI	CSH

SHIRE OF COLLIE

List of Accounts Submitted to Council - December 2019

Chq/EFT	Date	Name	Description	Amount	Bank	Type
66055456	22/11/2019	Landgate	Annual Subscription for SLIP Services 2019-20,	2,318.00	BENMUNI	INV
EFT27784	06/12/2019	Dy-mark	Carton (12) of White Line Marking paint aerosols 500g for depot stock	-	812.99	BENMUNI CSH
1166025	14/11/2019	Dy-mark	Carton (12) of White Line Marking paint aerosols 500g for depot stock, Carton (12) of White Spray & Mark paint aerosols 350g, Carton (12) of Yellow Line Marking paint aerosols 500g, Carton (12) of Yellow Spray & Mark paint aerosols 350g, Carton (12) of F/Pink Spray & Mark paint aerosols 350g	573.41	BENMUNI	INV
1166026	14/11/2019	Dy-mark	Carton (12) of Blue Line Marking paint aerosols 500g for depot stock, Carton (12) of Blue Spray & Mark paint aerosols 350g, Freight	239.58	BENMUNI	INV
EFT27785	06/12/2019	Dormakaba Australia Pty Ltd	Service auto doors	-	891.00	BENMUNI CSH
35WA-681975	10/10/2019	Dormakaba Australia Pty Ltd	Service auto doors, Service auto doors, Service auto doors, Service auto doors, Service auto doors	891.00	BENMUNI	INV
EFT27786	06/12/2019	Dynamic Security Management P/L	Alarm Call Out to Pound/Depot 30/08/2019	-	990.00	BENMUNI CSH
0001	30/09/2019	Dynamic Security Management P/L	Alarm Call Out to Pound/Depot 30/08/2019	330.00	BENMUNI	INV
0002	01/11/2019	Dynamic Security Management P/L	Alaram Call Out to Pound/Depot 14/10/2019, Alaram Call Out to Roche Park 17/10/2019	660.00	BENMUNI	INV
EFT27787	06/12/2019	Everlon Bronze	SINGLE GRANITE MONUMENT PLAQUE FOR PHILIP JOHN McCALLUM	-	315.26	BENMUNI CSH
00011108	30/09/2019	Everlon Bronze	SINGLE GRANITE MONUMENT PLAQUE FOR PHILIP JOHN McCALLUM	315.26	BENMUNI	INV
EFT27788	06/12/2019	Department Of Fire And Emergency Services	2019/20 ESL Quarter 2 In Accordance with the Department of Fire and Emergency Services of WA Act 1998 Part 6a- Emergency Services Levy- Section 36ZJ and Option B Agreement Arrangements	-	124,959.41	BENMUNI CSH

SHIRE OF COLLIE

List of Accounts Submitted to Council - December 2019

Chq/EFT	Date	Name	Description	Amount	Bank	Type
149917	21/11/2019	Department Of Fire And Emergency Services	2019/20 ESL Quarter 2 In Accordance with the Department of Fire and Emergency Services of WA Act 1998 Part 6a- Emergency Services Levy- Section 36ZJ and Option B Agreement Arrangements,	124,959.41	BENMUNI	INV
EFT27789	06/12/2019	Frontline Fire And Rescue	65657 BOOTS MAGNUM MENS SIZING Sz9.5 x 1, Sz10 x 1, Sz10.5 x 2, Sz 11.5 x 1, Sz12 x 1, Sz14.5 x 1 DFES - LGGS Funded	6,559.93	BENMUNI	CSH
65780	06/11/2019	Frontline Fire And Rescue	64921, 66830, 67085, 63412, 66849, BR9 White Helmet Complete - Heather O'Connor, Brett Rosel, Shannon Proudfoot, John Mattaboni, Rob Rusconi., DFES - LGGS Funded, 64921, 66830, 67085, 63412, 66849, BR9 Yelloe/Red Helmet Complete - Phil Bartolo, Kathy Miller., DFES - LGGS Funded, 64267 ESKA GLOVES - 3 x Sz7, 2 x Sz9, 1 x Sz10, DFES - LGGS Funded, 66-460+ZIP BOOTS OLIVER WILDFIRE WITH ZIP - 2 x Sz10.5, 1 x Sz12, DFES - LGGS Funded, 65657 BOOTS MAGNUM WOMENS SIZING - 1 x Sz8, DFES - LGGS Funded	3,174.28	BENMUNI	INV
65856	11/11/2019	Frontline Fire And Rescue	63407 BR9 Helmet Torch Base, DFES - LGGS Funded	119.63	BENMUNI	INV
65855	11/11/2019	Frontline Fire And Rescue	64921, 66830, 67085, 63412, 66849 BR9 White Helmet Complete Harry Winfield, Craig Martin, DFES - LGGS Funded, , 64921, 66830, 67085, 63412, 66849 BR9 Yellow/Red Stripe Helmet Complete Lachlan Martin, DFES - LGGS Funded, 64267 ESKA GLOVES Sz11 x 3, Sz10 x 1, Sz9 x 1, DFES - LGGS Funded, 65657 BOOTS MAGNUM MENS SIZING Sz9.5 x 1, Sz10 x 1, Sz10.5 x 2, Sz 11.5 x 1, Sz12 x 1, Sz14.5 x 1, DFES - LGGS Funded	2,994.32	BENMUNI	INV
65863	12/11/2019	Frontline Fire And Rescue	65657 BOOTS MAGNUM MENS SIZING Sz8 x 1, DFES - LGGS Funded	271.70	BENMUNI	INV

SHIRE OF COLLIE**List of Accounts Submitted to Council - December 2019**

Chq/EFT	Date	Name	Description	Amount	Bank	Type
EFT27790	06/12/2019	FIRE & SAFETY WA PTY LTD	Light Tanker rear of seat First Aid Kit mounting Satchels - DFES Specification DFES - LGGGS Funded	- 420.37	BENMUNI	CSH
34398	11/11/2019	FIRE & SAFETY WA PTY LTD	Light Tanker rear of seat First Aid Kit mounting Satchels - DFES Specification, DFES - LGGGS Funded	105.09	BENMUNI	INV
34411	12/11/2019	FIRE & SAFETY WA PTY LTD	Light Tanker rear of seat First Aid Kit mounting Satchels - DFES Specification, DFES - LGGGS Funded	315.28	BENMUNI	INV
EFT27791	06/12/2019	Fuji Xerox Australia Pty Ltd	Aministration Plotter Lease 16/12/2019 to 15/01/2019	- 410.30	BENMUNI	CSH
QA944334	21/11/2019	Fuji Xerox Australia Pty Ltd	Aministration Plotter Lease 16/12/2019 to 15/01/2019	410.30	BENMUNI	INV
EFT27792	06/12/2019	Golden West Pest & Weed Control	Please carry out pest treatment and termite inspections/treatment to shire building sites as per my 17 October 2019 email.	- 2,620.00	BENMUNI	CSH

SHIRE OF COLLIE**List of Accounts Submitted to Council - December 2019**

Chq/EFT	Date	Name	Description	Amount	Bank	Type
00012719	13/11/2019	Global Auto Electrical And Air Conditioning Services Pty Ltd	2009 HINO 500 SERIES TIPPER TRUCK AUTO (CO19468) - supply replacement master switch	107.94	BENMUNI	INV
00012762	15/11/2019	Global Auto Electrical And Air Conditioning Services Pty Ltd	CATERPILLAR 12H MOTOR GRADER (CO14596) - inspect and repair wiring issue	113.37	BENMUNI	INV
00012755	19/11/2019	Global Auto Electrical And Air Conditioning Services Pty Ltd	Inspect and rectify radio noise issue on Isuzu MU-X (113CO)	71.50	BENMUNI	INV
00012821	21/11/2019	Global Auto Electrical And Air Conditioning Services Pty Ltd	Remove dash, clean evaporator and refit to repair air con issue on Holden Colorado 2013 4x2 C/Cab LX Manual (CO485)	1,014.07	BENMUNI	INV
EFT27795	06/12/2019	G V KLEM PLANNING AND PROJECT MANAGEMENT	Planning and Project Management - Contract, Completion and Acquittal of Collie Motorplex Upgrade Stage 2	1,973.00	BENMUNI	CSH
0236	29/11/2019	G V KLEM PLANNING AND PROJECT MANAGEMENT	Planning and Project Management - Contract, Completion and Acquittal of Collie Motorplex Upgrade Stage 2	1,973.00	BENMUNI	INV
EFT27796	06/12/2019	Henderson Hardware	Please supply and deliver one 45kg gas bottle to the Velodrome Changerooms	1,117.45	BENMUNI	CSH
00021974	12/11/2019	Henderson Hardware	20mm x 50m roll garden poly pipe for reticulation repairs in Steere St	43.50	BENMUNI	INV
00021969	12/11/2019	Henderson Hardware	20m extension cable for depot store, 25m extension cable for depot store	77.80	BENMUNI	INV
00021970	12/11/2019	Henderson Hardware	1 x packet of paint rollers and 3 x paint brushes for painting of road nibs	74.74	BENMUNI	INV
00018696	14/11/2019	Henderson Hardware	1/2 MxF elbows for reticulation repairs at Central Park	49.38	BENMUNI	INV
00018794	14/11/2019	Henderson Hardware	25mm Philmac ball valves for reticulation repairs in Central Park, 25mm slipfix couplings for reticulation repairs in Central Park	121.77	BENMUNI	INV
00021540	14/11/2019	Henderson Hardware	Buckets for mixing of sulphur on River Walk construction	18.00	BENMUNI	INV
00021176	14/11/2019	Henderson Hardware	Riser 15x450mm for reticulation repairs at Shire office, Elbow 25x15fi, Elbow M&F 3/4	61.02	BENMUNI	INV

SHIRE OF COLLIE**List of Accounts Submitted to Council - December 2019**

Chq/EFT	Date	Name	Description	Amount	Bank	Type
00015316	14/11/2019	Henderson Hardware	25mm PVC coupling for reticulation repairs in CBD, 25mm PVC Telesco coupling for reticulation repairs	17.74	BENMUNI	INV
00015578	14/11/2019	Henderson Hardware	90 deg 75mm PVC elbow, 75mm PVC pipe, tube silicone, tube liquid nails for installation of key drop at depot, 1 x tube silicone, 1 x tube liquid nails for store stock	43.25	BENMUNI	INV
00018369	14/11/2019	Henderson Hardware	1/2 MxF elbows for reticulation repairs in Central Park	26.52	BENMUNI	INV
00018617	14/11/2019	Henderson Hardware	Bags of general purpose mortar for paving/footpath maintenance at Colliefields	52.80	BENMUNI	INV
00018508	14/11/2019	Henderson Hardware	Pine rail for repairs at Heritage Park	25.00	BENMUNI	INV
00010307	14/11/2019	Henderson Hardware	Please supply 1 litre of gloss white enamel paint for the hand rails at the swimming pool	35.00	BENMUNI	INV
00018409	14/11/2019	Henderson Hardware	Please supply 1 litre of Prep Right Stain Stopper for the Visitors Centre	38.27	BENMUNI	INV
00019248	14/11/2019	Henderson Hardware	Please supply 1 x s-trap and 2 x pvc fittings for the Bandhall	13.66	BENMUNI	INV
00011709	14/11/2019	Henderson Hardware	Please supply and deliver one 45kg gas bottle to the Velodrome Changerooms	145.00	BENMUNI	INV
00019609	14/11/2019	Henderson Hardware	Sheet of F52 reinforcing mesh for Worsley Fire Station disabled hardstand	144.00	BENMUNI	INV
00022216	14/11/2019	Henderson Hardware	Blue paint for marking of Acrod bay at Cardiff Fire Station, Blue paint for marking of Acrod bay at Worsley Fire Station	130.00	BENMUNI	INV
EFT27797	06/12/2019	It Vision	IT VISION TO INVESTIGATE IMBALANCE OF PENSIONER RECONCILIATION	-	1,100.00	BENMUNI CSH
32453	19/11/2019	It Vision	IT VISION TO INVESTIGATE IMBALANCE OF PENSIONER RECONCILIATION,	-	1,100.00	BENMUNI INV
EFT27798	06/12/2019	Collie Italian & Sporting Club Inc	Catering for SPOTY Awards 80 @ \$15	-	1,200.00	BENMUNI CSH
75	22/11/2019	Collie Italian & Sporting Club Inc	Catering for SPOTY Awards 80 @ \$15	-	1,200.00	BENMUNI INV
EFT27799	06/12/2019	Ian Guppy & Co Smash Repairs	Insurance Excess for CO30167 Claim Number 6006246	-	697.90	BENMUNI CSH

SHIRE OF COLLIE**List of Accounts Submitted to Council - December 2019**

Chq/EFT	Date	Name	Description	Amount	Bank	Type
62825	15/11/2019	Ian Guppy & Co Smash Repairs	Insurance Excess for CO30167 , Claim Number 6006246	300.00	BENMUNI	INV
62824	18/11/2019	Ian Guppy & Co Smash Repairs	Insurance Excess for CO30167 , Claim Number 6006238	300.00	BENMUNI	INV
62833	20/11/2019	Ian Guppy & Co Smash Repairs	2009 HINO 500 SERIES TIPPER TRUCK AUTO (CO19468) - Remove faulty drivers side seat belt and replace with new supplied belt (safety issue)	97.90	BENMUNI	INV
EFT27800	06/12/2019	Connect CCS	Overcalls fee for contract CA0184 for month of October 2019	-	413.99	BENMUNI CSH
00099159	15/11/2019	Connect CCS	Overcalls fee for contract CA0184 for month of October 2019 ,	413.99	BENMUNI	INV
EFT27801	06/12/2019	Jason Signmakers	Street sign brackets JTB-60	-	537.37	BENMUNI CSH
200205	23/08/2019	Jason Signmakers	Street sign brackets JTB-60, Uni brackets TD1-Uni-60	344.30	BENMUNI	INV
201459	27/09/2019	Jason Signmakers	Snake warning signs 300x300 2.0 Aluminium crop corners class 2 Black on Yellow background UV overlamine for Soldiers park.	153.47	BENMUNI	INV
202971	13/11/2019	Jason Signmakers	Hydrochloric Acid, UN No1789, Hazchem 2R, Corrosive 8, metal sign, 800mm W x 400mm L for water park container signage	39.60	BENMUNI	INV
EFT27802	06/12/2019	South West Isuzu	Filters for service of 2011 Isuzu NPR 300 Crew Cab Tipper (CO783) - oil filter 8983282070	-	75.41	BENMUNI CSH
839220	21/11/2019	South West Isuzu	Filters for service of 2011 Isuzu NPR 300 Crew Cab Tipper (CO783) - oil filter 8983282070, Fuel filter 92956471	75.41	BENMUNI	INV
EFT27803	06/12/2019	Jax Corner Deli & Diner	Light lunch for 12 persons to farewell staff member and celebrate milestones.	-	150.00	BENMUNI CSH
IV00000000045	19/11/2019	Jax Corner Deli & Diner	Light lunch for 12 persons to farewell staff member and celebrate milestones.	150.00	BENMUNI	INV
EFT27804	06/12/2019	Kings Tree Care	Western Power clearance pruning as directed by P&G Supervisor	-	2,464.00	BENMUNI CSH
00006383	14/11/2019	Kings Tree Care	Western Power clearance pruning as directed by P&G Supervisor	2,464.00	BENMUNI	INV

SHIRE OF COLLIE

List of Accounts Submitted to Council - December 2019

Chq/EFT	Date	Name	Description	Amount	Bank	Type
EFT27805	06/12/2019	Lotex Filter Cleaning Service	Clean filters	-	241.80	BENMUNI CSH
00005152	09/10/2019	Lotex Filter Cleaning Service	Clean filters		159.49	BENMUNI INV
00005154	23/10/2019	Lotex Filter Cleaning Service	Clean filters		82.31	BENMUNI INV
EFT27806	06/12/2019	Living Springs	5 large bottles of water for library water cooler	-	55.00	BENMUNI CSH
136379	15/11/2019	Living Springs	5 large bottles of water for library water cooler		55.00	BENMUNI INV
EFT27807	06/12/2019	Landmark Operations Ltd	2.5kg container of rabbit control baits for Wallsend Ground	-	77.00	BENMUNI CSH
902252263	09/10/2019	Landmark Operations Ltd	2.5kg container of rabbit control baits for Wallsend Ground		77.00	BENMUNI INV
EFT27808	06/12/2019	Collie River Valley Little Athletics Centre Inc	Collie Community Small Grants Recipient	-	3,600.00	BENMUNI CSH
3	03/12/2019	Collie River Valley Little Athletics Centre Inc	Collie Community Small Grants Recipient		3,600.00	BENMUNI INV
EFT27809	06/12/2019	Malatesta Road Paving & Hot Mix	Supply and apply two coat seal bitumen and 10/ 7mm aggregate for Shannon Road	-	44,275.80	BENMUNI CSH
I35535	21/11/2019	Malatesta Road Paving & Hot Mix	Supply and apply bitumen and 10mm aggregate for Shannon Road, Supply and apply two coat seal bitumen and 10/ 7mm aggregate for Shannon Road		24,113.70	BENMUNI INV
I35539	22/11/2019	Malatesta Road Paving & Hot Mix	Supply and apply bitumen and 10mm aggregate for Shannon Road, Supply and apply two coat seal bitumen and 10/ 7mm aggregate for Shannon Road		4,223.20	BENMUNI INV
I35540	22/11/2019	Malatesta Road Paving & Hot Mix	Supply and apply bitumen and 10mm aggregate to Hodd Road construction, Supply and apply bitumen and 2 coat seal with 10/7mm aggregate to Hodd Road construction		6,891.50	BENMUNI INV
I35541	22/11/2019	Malatesta Road Paving & Hot Mix	Supply and apply bitumen and 10mm aggregate to Hodd Road construction, Supply and apply bitumen and 2 coat seal with 10/7mm aggregate to Hodd Road construction		9,047.40	BENMUNI INV

SHIRE OF COLLIE**List of Accounts Submitted to Council - December 2019**

Chq/EFT	Date	Name	Description	Amount	Bank	Type
EFT27810	06/12/2019	Collie Canvas And Camping	PPE Kit Bags as Per LGGG Capital Grants application DFES - LGGG Approved Capital Grant Line 9 Item	- 3,643.60	BENMUNI	CSH
73047	13/11/2019	Collie Canvas And Camping	PPE Kit Bags as Per LGGG Capital Grants application, DFES - LGGG Approved Capital Grant Line 9 Item	3,484.80	BENMUNI	INV
73137	18/11/2019	Collie Canvas And Camping	Drovers hat for employee #480	30.80	BENMUNI	INV
73139	18/11/2019	Collie Canvas And Camping	Drovers hats for use during site inspections - stock	128.00	BENMUNI	INV
EFT27812	06/12/2019	Ozarb Tree Service	Remove all trees (marked yellow) along fence line on Lyall St Road Reserve commencing 05/11	- 4,800.00	BENMUNI	CSH
51	10/10/2019	Ozarb Tree Service	Remove 1 x pine tree, prune various trees on Palmer/Williams Rd corner to clear sight line issue	1,500.00	BENMUNI	INV
56	13/11/2019	Ozarb Tree Service	Remove all trees (marked yellow) along fence line on Lyall St Road Reserve commencing 05/11	3,300.00	BENMUNI	INV
EFT27813	06/12/2019	Pilatti Bros Transport	10T limestone for general road maintenance	- 319.00	BENMUNI	CSH
INV-2407	15/11/2019	Pilatti Bros Transport	10T limestone for general road maintenance	319.00	BENMUNI	INV
EFT27814	06/12/2019	Phoenix Glass	For repair of window at Waster Transfer Site - Weighbridge Hut	- 130.00	BENMUNI	CSH
00034774	19/11/2019	Phoenix Glass	For repair of window at Waster Transfer Site - Weighbridge Hut	130.00	BENMUNI	INV
EFT27815	06/12/2019	Pak-it Computers	MFC-L3770CDW Brother Multi Function A4 Colour Laser DFES - LGGG Funded	- 1,298.00	BENMUNI	CSH
A5837	17/09/2019	Pak-it Computers	Supply keyboard & mouse como for Technical Officer	40.00	BENMUNI	INV
A5863	01/10/2019	Pak-it Computers	KBRP-9500M-BLAC RAPOO 9500M Keyboard and Mouse Combo, DFES - LGGG Funded	114.00	BENMUNI	INV
A5961	12/11/2019	Pak-it Computers	MFC-L3770CDW Brother Multi Function A4 Colour Laser, DFES - LGGG Funded	579.00	BENMUNI	INV
A5990	20/11/2019	Pak-it Computers	1 x Council Photo for Chambers	15.00	BENMUNI	INV

SHIRE OF COLLIE**List of Accounts Submitted to Council - December 2019**

Chq/EFT	Date	Name	Description	Amount	Bank	Type
A6006	28/11/2019	Pak-it Computers	Run 2 x cable from server rack in library to undercroft with 2 data ports on wall for computer and ip phones.	350.00	BENMUNI	INV
A6032	05/12/2019	Pak-it Computers	MS-Office Home 2019 , DFES - LGGS Approved Overspend	200.00	BENMUNI	INV
EFT27816	06/12/2019	PJ Wright & Associates Pty Ltd T/F the PJ Wright Family Trust	Carry out site investigation and design for Collie River Valley Toursit Park in accordance with your fee proposal #PROF - 2172 dated 8 May 2019.	3,454.00	BENMUNI	CSH
INV-4547	18/11/2019	PJ Wright & Associates Pty Ltd T/F the PJ Wright Family Trust	Carry out site investigation and design for Collie River Valley Toursit Park in accordance with your fee proposal #PROF 2172 dated 8 May 2019.	3,454.00	BENMUNI	INV
EFT27817	06/12/2019	P & S Griggs Plumbing	Please repair leak in ensuite vanity unit at 43 Elouera Rd, Collie. Please arrange access with Jackie Stocks at Elders - Real Estate	294.69	BENMUNI	CSH
4985	20/11/2019	P & S Griggs Plumbing	Please repair leak in ensuite vanity unit at 43 Elouera Rd, Collie. Please arrange access with Jackie Stocks at Elders - Real Estate	294.69	BENMUNI	INV
EFT27818	06/12/2019	Pathwest	Fit for work - Pathology	246.06	BENMUNI	CSH
11017277	19/10/2019	Pathwest	Fit for work - Pathology	246.06	BENMUNI	INV
EFT27819	06/12/2019	Piavanini Welding	2009 HINO 500 SERIES TIPPER TRUCK AUTO (CO19468) - repair tailgate pin (safety issues)	1,254.00	BENMUNI	CSH
00010961	30/09/2019	Piavanini Welding	Mitsubishi Fuso FV51 Tip Truck (CO785) - repair tailgate lock mechanism	247.50	BENMUNI	INV
00010960	30/09/2019	Piavanini Welding	2009 HINO 500 SERIES TIPPER TRUCK AUTO (CO19468) - repair tailgate pin (safety issues)	704.00	BENMUNI	INV
00011090	18/11/2019	Piavanini Welding	Fabricate 1 pair of blades for Slasher (Agrizzi)	302.50	BENMUNI	INV
EFT27820	06/12/2019	Collie Betta Home Living	Colour printer cartridge 61XL for workshop printer	155.85	BENMUNI	CSH
19810005728	12/11/2019	Collie Betta Home Living	Colour printer cartridge 61XL for workshop printer, Black printer cartridge 61XL for workshop printer	115.90	BENMUNI	INV

SHIRE OF COLLIE**List of Accounts Submitted to Council - December 2019**

Chq/EFT	Date	Name	Description	Amount	Bank	Type
19810005931	20/11/2019	Collie Betta Home Living	Logitech keyboard for workshop PC to replace damaged item	39.95	BENMUNI	INV
EFT27821	06/12/2019	Rose & Crown Hotel	3 Nighths Accommodation-Ranger	-	631.50	BENMUNI CSH
63200	22/11/2019	Rose & Crown Hotel	3 Nighths Accommodation-Ranger	-	631.50	BENMUNI INV
EFT27822	06/12/2019	Red Dot Stores	Lights for Xmas Lanterns for recycled xmas lights project to light up the overhead paedestrian bridge	-	102.00	BENMUNI CSH
43409911	20/11/2019	Red Dot Stores	Lights for Xmas Lanterns for recycled xmas lights project to light up the overhead paedestrian bridge	-	102.00	BENMUNI INV
EFT27823	06/12/2019	Sheridan's	Name Badges for Councillors, Shire President and Deputy Shire President with new Shire of Collie logo.	-	391.71	BENMUNI CSH
78735	15/11/2019	Sheridan's	Name Badges for Councillors, Shire President and Deputy Shire President with new Shire of Collie logo.	-	391.71	BENMUNI INV
EFT27824	06/12/2019	Bunbury Trucks	Replace R/H leaf springs and R/H rear axle seal on 'Mercedes Benz Stirling 10T TipTruck (0075CO)	-	5,715.90	BENMUNI CSH
BUCSY169588	05/11/2019	Bunbury Trucks	Replace R/H leaf springs and R/H rear axle seal on 'Mercedes Benz Stirling 10T TipTruck (0075CO)	-	5,216.20	BENMUNI INV
123685Y	14/11/2019	Bunbury Trucks	2009 HINO 500 SERIES TIPPER TRUCK AUTO (CO19468) - supply right hand front seat belt to replace faulty item	-	437.24	BENMUNI INV
123740Y	19/11/2019	Bunbury Trucks	2010 Mitsubishi Fuso Canter 4.0 LWB (CO11200) - lube kit for service MH-FLK13	-	62.46	BENMUNI INV
EFT27826	06/12/2019	Southern Lock & Security	X" lock for Recreation Ground"	-	755.00	BENMUNI CSH
B11744	12/11/2019	Southern Lock & Security	X" lock for Roche Park Cricket	-	755.00	BENMUNI INV
EFT27827	06/12/2019	Station Motors 1974	Service kit (oil filter, fuel filters and oil) for 24000km service of Holden Colorado 4x4 CR/Cab CHAS LX 2.8I (108CO)	-	345.59	BENMUNI CSH
20395	21/11/2019	Station Motors 1974	Service kit (oil filter, fuel filters and oil) for 24000km service of Holden Colorado 4x4 CR/Cab CHAS LX 2.8I (108CO)	-	345.59	BENMUNI INV

SHIRE OF COLLIE**List of Accounts Submitted to Council - December 2019**

Chq/EFT	Date	Name	Description	Amount	Bank	Type
EFT27828	06/12/2019	Stewart & Heaton Clothing Co Pty Ltd	J795-GLD, T781-GLD + Badges as per order forms - Worsley BFB 7 Members, 2 full kit, 4 x badges only DFES - LGGS Funded	3,856.97	BENMUNI	CSH
SIN-3107716	27/09/2019	Stewart & Heaton Clothing Co Pty Ltd	J795-GLD, T781-GLD + Badges as per order forms - Worsley BFB 7 Members, 2 full kit, 4 x badges only, DFES - LGGS Funded, J795-GLD, T781-GLD + Badges as per order forms - Cardiff BFB 2 Members, DFES - LGGS Funded, J795-GLD, T781-GLD + Badges as per order forms - Collie Preston BFB 4 Members, DFES - LGGS Funded, J795-GLD, T781-GLD + Badges as per order forms - Allanson BFB 1 Member, DFES - LGGS Funded, T243 Trousers - 2 x 92R, 2 x 87S, DFES - LGGS Funded	1,561.55	BENMUNI	INV
SIN-3110691	04/10/2019	Stewart & Heaton Clothing Co Pty Ltd	J795-GLD, T781-GLD + Badges as per order forms - Worsley BFB 7 Members, 2 full kit, 4 x badges only, DFES - LGGS Funded, J795-GLD, T781-GLD + Badges as per order forms - Cardiff BFB 2 Members, DFES - LGGS Funded, J795-GLD, T781-GLD + Badges as per order forms - Collie Preston BFB 4 Members, DFES - LGGS Funded, J795-GLD, T781-GLD + Badges as per order forms - Allanson BFB 1 Member, DFES - LGGS Funded, T243 Trousers - 2 x 92R, 2 x 87S, DFES - LGGS Funded	1,814.47	BENMUNI	INV

SHIRE OF COLLIE

List of Accounts Submitted to Council - December 2019

Chq/EFT	Date	Name	Description	Amount	Bank	Type
SIN-3115542	15/10/2019	Stewart & Heaton Clothing Co Pty Ltd	J795-GLD, T781-GLD + Badges as per order forms - Worsley BFB 7 Members, 2 full kit, 4 x badges only, DFES - LGGS Funded, J795-GLD, T781-GLD + Badges as per order forms - Cardiff BFB 2 Members, DFES - LGGS Funded, J795-GLD, T781-GLD + Badges as per order forms - Collie Preston BFB 4 Members, DFES - LGGS Funded, J795-GLD, T781-GLD + Badges as per order forms - Allanson BFB 1 Member, DFES - LGGS Funded, T243 Trousers - 2 x 92R, 2 x 87S, DFES - LGGS Funded	229.37	BENMUNI	INV
SIN-3128311	13/11/2019	Stewart & Heaton Clothing Co Pty Ltd	J795-GLD, T781-GLD + Badges as per order forms - Collieturn Cardiff BFB 1 Member Full Kit, DFES - LGGS Funded	133.47	BENMUNI	INV
SIN-3131346	20/11/2019	Stewart & Heaton Clothing Co Pty Ltd	J795-GLD, T781-GLD + Badges as per order forms - Allanson BFB 1 Member, full kit, DFES - LGGS Funded	118.11	BENMUNI	INV
EFT27829	06/12/2019	Snap On Tools	IR Thermometer for checking of pump temperatures in Water Park and irrigation pumps	-	BENMUNI	CSH
11141999811	14/11/2019	Snap On Tools	IR Thermometer for checking of pump temperatures in Water Park and irrigation pumps	377.86	BENMUNI	INV
EFT27830	06/12/2019	Sunny Sign Company Pty Ltd	200mm street signs with shire logo, pointed - YOURDAMUNG RD, QUINNS RD, SHOTTS RIVER RD, BACON ST, SHOTTS RD	924.00	BENMUNI	CSH
422050	12/11/2019	Sunny Sign Company Pty Ltd	Roll of red reflective tape CL1 100mm x 45.7m for pine bollards on River Walk Stage 3	165.00	BENMUNI	INV

SHIRE OF COLLIE

List of Accounts Submitted to Council - December 2019

Chq/EFT	Date	Name	Description	Amount	Bank	Type
422586	19/11/2019	Sunny Sign Company Pty Ltd	200mm street signs with shire logo, pointed - YOURDAMUNG RD, QUINNS RD, SHOTTS RIVER RD, BACON ST, SHOTTS RD, 150mm street signs with shire logo, pointed - GLEN RD, WYVERN RD, STEERE RD, PITT ST, ASH MEWS, 200mm street signs with shire logo, square - POWERHOUSE RD, 150mm street signs with shire logo, square - CRAMPTON ST, HODDELL RD, ROWLANDS RD	759.00	BENMUNI	INV
EFT27831	06/12/2019	South West Fire Units	Allanson 3.4U B Service and Brakes and Lines Replacement - DFES - LGGS Approved Overspend	26,774.56	BENMUNI	CSH
I32883	13/11/2019	South West Fire Units	Please go ahead with your quotation to fabricate hand rails for the rear stairs at the Administration Building	3,347.72	BENMUNI	INV
I32901	14/11/2019	South West Fire Units	Supply nozzle for 300ltr tank with Davey pump and hose reel	69.01	BENMUNI	INV
I32911	15/11/2019	South West Fire Units	Repair Comms Box and bent Guard Collie Preston 2.4, DFES - LGGS Funded, Replace Fuel Line Collieburn Cardiff 1.4, DFES - LGGS Funded	194.87	BENMUNI	INV
I32910	15/11/2019	South West Fire Units	Repair Comms Box and bent Guard Collie Preston 2.4, DFES - LGGS Funded, Replace Fuel Line Collieburn Cardiff 1.4, DFES - LGGS Funded	909.85	BENMUNI	INV
I32931	20/11/2019	South West Fire Units	Allanson 3.4U B Service and Brakes and Lines Replacement, DFES - LGGS Approved Overspend	22,253.11	BENMUNI	INV
EFT27832	06/12/2019	Scope Business Imaging	Admin Colour Photocopier Preventative Service Plan and Help Desk Support for 30/09/2019	4,909.63	BENMUNI	CSH
470327	30/09/2019	Scope Business Imaging	Admin Colour Photocopier Preventative Service Plan and Help Desk Support for 30/09/2019,	2,354.37	BENMUNI	INV
470328	30/09/2019	Scope Business Imaging	Photocopier Preventative Service Plan and Help Desk Support for Library 31/09/2019 ,	170.75	BENMUNI	INV
476899	30/11/2019	Scope Business Imaging	Admin Colour Photocopier Preventative Service Plan and Help Desk Support for 30/11/2019 ,	2,186.14	BENMUNI	INV

SHIRE OF COLLIE

List of Accounts Submitted to Council - December 2019

Chq/EFT	Date	Name	Description	Amount	Bank	Type
476901	30/11/2019	Scope Business Imaging	Photocopier Preventative Service Plan and Help Desk Support for Library 30/11/2019 ,	198.37	BENMUNI	INV
EFT27833	06/12/2019	Sigma Chemicals	25 Bags of Sodium Bicarbonate	-	517.00	BENMUNI CSH
134139/01	19/11/2019	Sigma Chemicals	25 Bags of Sodium Bicarbonate	-	517.00	BENMUNI INV
EFT27834	06/12/2019	Stanley Family Trust T/a Gumfire Marketing	Please supply Business Cards for Shire President and Deputy Shire President, Information Services Manager and Community Development Officer as per the Shire of Collie template with the new logo.	-	800.80	BENMUNI CSH
INV-10135	18/11/2019	Stanley Family Trust T/a Gumfire Marketing	Please supply Business Cards for Shire President and Deputy Shire President, Information Services Manager and Community Development Officer as per the Shire of Collie template with the new logo.	-	800.80	BENMUNI INV
EFT27835	06/12/2019	Collie SignFX	200 Non Residential Bin Stickers	-	1,495.00	BENMUNI CSH
INV-3800	15/10/2019	Collie SignFX	Updated entrance sign for Collie Mineworkers Memorial Swimming Pool with new opening hours and entry fees.	-	165.00	BENMUNI INV
INV-3801	15/10/2019	Collie SignFX	200 Non Residential Bin Stickers	-	770.00	BENMUNI INV
INV-3857	19/11/2019	Collie SignFX	Waste Education Banner	-	120.00	BENMUNI INV
INV-3855	19/11/2019	Collie SignFX	Change letters and numbers on 2 x 1850(w)x500mm(h) signs to be used on Patstone Rd construction	-	440.00	BENMUNI INV
EFT27836	06/12/2019	State Law Publisher	Notices for the Gazette: Firebreak & Fuel Hazard Reduction Notice 2019 - 2020 and Notice of Appointment Stevie Thompson - Ranger Services	-	563.44	BENMUNI CSH
162874	20/11/2019	State Law Publisher	Notices for the Gazette: Firebreak & Fuel Hazard Reduction Notice 2019 - 2020 and Notice of Appointment Stevie Thompson - Ranger Services	-	563.44	BENMUNI INV
EFT27837	06/12/2019	Stuart Russell Romero	MOVAT Software for Collie SES Unit + Setup DFES - LGGS Approved Overspend	-	512.50	BENMUNI CSH
125	18/11/2019	Stuart Russell Romero	MOVAT Software for Collie SES Unit + Setup, DFES - LGGS Approved Overspend	-	362.50	BENMUNI INV

SHIRE OF COLLIE

List of Accounts Submitted to Council - December 2019

Chq/EFT	Date	Name	Description	Amount	Bank	Type
136	02/12/2019	Stuart Russell Romero	MOVAT Software for Collie SES Unit + Setup, DFES - LGGS Approved Overspend	150.00	BENMUNI	INV
EFT27838	06/12/2019	South Regional Tafe	resource and tuition fees - Stevie Thompson TAFE	-	246.25	BENMUNI CSH
I0010045	18/11/2019	South Regional Tafe	resource and tuition fees - Stevie Thompson TAFE		246.25	BENMUNI INV
EFT27839	06/12/2019	Winc Australia Pty Ltd	12 x A4 Reflex Photocopy Paper	-	1,394.73	BENMUNI CSH
9900858252	05/10/2019	Winc Australia Pty Ltd	2 x Box A3 White Reflex Photocopy Paper, 3 x Scissors, 1 x Pkt Magnetic Dots, 1 x Hole Punch, 10 x Correction Tape		43.73	BENMUNI INV
9900877690	11/11/2019	Winc Australia Pty Ltd	2 x boxes of copy paper		55.53	BENMUNI INV
9900877955	12/11/2019	Winc Australia Pty Ltd	4 x pkts 100 Leathergrain Binding Covers A4 Black, 4 x pkts 100 Binding Covers A4 Clear, 2 x 32mm 50 Fellows Plastic Binding Covers A4 21hole Black, 2 x 25mm 50 Fellows Plastic Binding Covers A4 21hole Black		237.82	BENMUNI INV
9900878254	13/11/2019	Winc Australia Pty Ltd	4 x pkts 100 Leathergrain Binding Covers A4 Black, 4 x pkts 100 Binding Covers A4 Clear, 2 x 32mm 50 Fellows Plastic Binding Covers A4 21hole Black, 2 x 25mm 50 Fellows Plastic Binding Covers A4 21hole Black		80.17	BENMUNI INV
9900878255	13/11/2019	Winc Australia Pty Ltd	Book covering tape x 10 rolls		86.79	BENMUNI INV
9900880129	20/11/2019	Winc Australia Pty Ltd	12 x A4 Reflex Photocopy Paper, 3 x Assorted Push Pins, 2 x Post-It Notes Pop-up Cabinet Packs, 1 x 6 Pkt Clearing Packing Tape, 1 x 10 Pkt Writing Pads A4 Ruled		495.10	BENMUNI INV
9900880128	20/11/2019	Winc Australia Pty Ltd	1 x Fellows Shredder 60CS, 3 x A4 Laminating Pouches 80 Mic, 4 x Pkts Key Tags, 5 x 25mm Fold back clips, 5 x 32mm Fold back clips, 5 x 15mm Fold back clips, 5 x Invisible Tape 18mm x 33m		295.21	BENMUNI INV
9900880756	22/11/2019	Winc Australia Pty Ltd	1 x Pool - Key Cabinet		100.38	BENMUNI INV
EFT27840	06/12/2019	Southwest Oil Supplies	205ltr containers of Delo Gold 15w/40 engine oil for workshop stock	-	2,789.60	BENMUNI CSH
00004061	17/11/2019	Southwest Oil Supplies	205ltr containers of Delo Gold 15w/40 engine oil for workshop stock		1,845.80	BENMUNI INV

SHIRE OF COLLIE**List of Accounts Submitted to Council - December 2019**

Chq/EFT	Date	Name	Description	Amount	Bank	Type
00004062	17/11/2019	Southwest Oil Supplies	205ltr container of Torque Force 50 for workshop stock	943.80	BENMUNI	INV
EFT27841	06/12/2019	The Royal Life Saving Society Of WA	3 x Pool Life Guard Bum Bags.	-	114.25	BENMUNI CSH
106959	20/11/2019	The Royal Life Saving Society Of WA	3 x Pool Life Guard Bum Bags.	-	114.25	BENMUNI INV
EFT27842	06/12/2019	T-Quip	Outer air filters TOP108-3810 for Toro Groundsmaster 360 D/Cab 4wd with rear discharge cutting deck (CO30537)	-	67.75	BENMUNI CSH
88409#5	19/11/2019	T-Quip	Outer air filters TOP108-3810 for Toro Groundsmaster 360 D/Cab 4wd with rear discharge cutting deck (CO30537)	-	67.75	BENMUNI INV
EFT27843	06/12/2019	Tyrepower	4 x tyres 104CO Mazda CX-5	-	960.00	BENMUNI CSH
3265430	18/11/2019	Tyrepower	4 x tyres 104CO Mazda CX-5	-	960.00	BENMUNI INV
EFT27844	06/12/2019	TBS Rural & Hardware	20ltr containers of Roundup Biactive for stock	-	789.00	BENMUNI CSH
OEI89644	31/10/2019	TBS Rural & Hardware	New grinding wheel for pedistal grinder in workshop	-	25.00	BENMUNI INV
OEI89652	11/11/2019	TBS Rural & Hardware	20ltr containers of Roundup Biactive for stock	-	740.00	BENMUNI INV
OEI89653	13/11/2019	TBS Rural & Hardware	Box of cutting discs for workshop stock	-	24.00	BENMUNI INV
EFT27845	06/12/2019	Terresa Briggs	Reimbursement of ST John Ambulance First Aid Course	-	246.48	BENMUNI CSH
22112019	22/11/2019	Terresa Briggs	Reimbursement of Les Mills Music and Chorography, , Reimbursement of ST John Ambulance First Aid Course,	-	246.48	BENMUNI INV
EFT27846	06/12/2019	Topgrade Holdings	3 x 2.5Ltr Sapphire No. 8 Cleaner Sanitizer	-	318.28	BENMUNI CSH
17343	11/11/2019	Topgrade Holdings	3 x 2.5Ltr Sapphire No. 8 Cleaner Sanitizer	-	318.28	BENMUNI INV
EFT27847	06/12/2019	Little Tipper	Supply Sound System for Seniors Week at Roche Park	-	300.00	BENMUNI CSH
54	15/11/2019	Little Tipper	Supply Sound System for Seniors Week at Roche Park	-	300.00	BENMUNI INV
EFT27849	06/12/2019	Toll Transport Pty Ltd	Freight Deliveries to Admin 08/11/2019 to 08/11/2019	-	545.22	BENMUNI CSH
0436-S280142	13/10/2019	Toll Transport Pty Ltd	Freight Deliveries to Depot 07/10/2019 to 10/10/2019 , , Freight Deliveries to Admin 07/10/2019 ,	-	84.92	BENMUNI INV
0438-S280142	27/10/2019	Toll Transport Pty Ltd	Freight Deliveries to Depot 25/10/2019 , , Freight Deliveries to Admin 25/10/2019 ,	-	230.18	BENMUNI INV

SHIRE OF COLLIE

List of Accounts Submitted to Council - December 2019

Chq/EFT	Date	Name	Description	Amount	Bank	Type
0440-S280142	10/11/2019	Toll Transport Pty Ltd	Freight Deliveries to Depot 04/11/2019 to 06/11/2019 , , Freight Deliveries to Admin 08/11/2019 to 08/11/2019 ,	230.12	BENMUNI	INV
EFT27850	06/12/2019	Collie River Valley Medical Centre	Fitness for work 497 and 280	-	198.00	BENMUNI CSH
446672BS1	19/11/2019	Collie River Valley Medical Centre	Fitness for work 497 and 280,	49.50	BENMUNI	INV
446621BS1	19/11/2019	Collie River Valley Medical Centre	fitness for work - per/420	49.50	BENMUNI	INV
446810IV	20/11/2019	Collie River Valley Medical Centre	Fitness for work 497 and 280,	49.50	BENMUNI	INV
446755IV	20/11/2019	Collie River Valley Medical Centre	Fitness for work - Drug and Alcohol - Employee #541	49.50	BENMUNI	INV
EFT27851	06/12/2019	Westrac Equipment Pty Ltd	Caterpillar 428E2 Backhoe Loader (CO30051) - travel from Bunbury to Collie and return to check ride control fault	-	1,942.91	BENMUNI CSH
SI1450269	11/11/2019	Westrac Equipment Pty Ltd	Caterpillar 428E2 Backhoe Loader (CO30051) - travel from Bunbury to Collie and return to check ride control fault	1,609.60	BENMUNI	INV
PI4006795	13/11/2019	Westrac Equipment Pty Ltd	Parts to remove loader frame wear on 2011 Caterpillar 924H Loader (1DQY895) - shim 194-7109, Shim 194-7111, Shim 194-7112, Shim 271-3222, Freight ex Melb	255.01	BENMUNI	INV
PI4010721	14/11/2019	Westrac Equipment Pty Ltd	Parts to remove loader frame wear on 2011 Caterpillar 924H Loader (1DQY895) - shim 194-7109, Shim 194-7111, Shim 194-7112, Shim 271-3222, Freight ex Melb	19.65	BENMUNI	INV
PI4010720	14/11/2019	Westrac Equipment Pty Ltd	Parts to remove loader frame wear on 2011 Caterpillar 924H Loader (1DQY895) - shim 194-7109, Shim 194-7111, Shim 194-7112, Shim 271-3222, Freight ex Melb	12.03	BENMUNI	INV
PI4016665	16/11/2019	Westrac Equipment Pty Ltd	Parts to remove loader frame wear on 2011 Caterpillar 924H Loader (1DQY895) - shim 194-7109, Shim 194-7111, Shim 194-7112, Shim 271-3222, Freight ex Melb	46.62	BENMUNI	INV
EFT27852	06/12/2019	WA Rangers Association	WA Rangers Association Legal Workshop	-	200.00	BENMUNI CSH
13	16/11/2019	WA Rangers Association	WA Rangers Association Legal Workshop	200.00	BENMUNI	INV
EFT27853	06/12/2019	Collie Bin Hire	Supply and empty skip bins at Minnipup Pool, Black Diamond and Shire Depot, Financial year 2019/20	-	440.00	BENMUNI CSH

SHIRE OF COLLIE

List of Accounts Submitted to Council - December 2019

Chq/EFT	Date	Name	Description	Amount	Bank	Type
7491	31/10/2019	Collie Bin Hire	Supply and empty skip bins at Minninup Pool, Black Diamond and Shire Depot, Financial year 2019/20	440.00	BENMUNI	INV
EFT27854	06/12/2019	WA COUNTRY BUILDERS	Kerb Bond Refund- Unit 7 Homemaker Centre CNR Blair and Strickland Street Bunbury WA 6230	- 500.00	BENMUNI	CSH
KERBBOND REFUND	15/11/2019	WA COUNTRY BUILDERS	Kerb Bond Refund- Unit 7 Homemaker Centre CNR Blair and Strickland Street Bunbury WA 6230	500.00	BENMUNI	INV
EFT27855	06/12/2019	WESTERN AUSTRALIAN ENDURANCE RIDERS ASSOCIATION	Community Small Grant Recipient	- 5,000.00	BENMUNI	CSH
0023	16/11/2019	WESTERN AUSTRALIAN ENDURANCE RIDERS ASSOCIATION	Community Small Grant Recipient	5,000.00	BENMUNI	INV
EFT27856	06/12/2019	WA TREASURY CORPORATION	Principal Loan 119 Repayment	- 7,687.23	BENMUNI	CSH
30092019	30/09/2019	WA TREASURY CORPORATION	Principal Loan 119 Repayment, , Interest on Loan 119,	7,687.23	BENMUNI	INV
EFT27857	10/12/2019	WA SUPER	Superannuation contributions	- 21,722.85	BENMUNI	CSH
22082018	28/08/2018	WA SUPER		500.00		INV
22082018	28/08/2018	WA SUPER		- 500.00	BENMUNI	INV
SUPER	18/09/2019	WA SUPER		18,830.78	BENMUNI	INV
DEDUCTION	18/09/2019	WA SUPER		442.63	BENMUNI	INV
DEDUCTION	18/09/2019	WA SUPER		1,552.62	BENMUNI	INV
DEDUCTION	18/09/2019	WA SUPER		20.00	BENMUNI	INV
DEDUCTION	18/09/2019	WA SUPER		120.62	BENMUNI	INV
DEDUCTION	18/09/2019	WA SUPER		233.00	BENMUNI	INV
DEDUCTION	18/09/2019	WA SUPER		100.00	BENMUNI	INV
DEDUCTION	18/09/2019	WA SUPER		377.67	BENMUNI	INV
SUPER	18/09/2019	WA SUPER		45.53	BENMUNI	INV
EFT27858	10/12/2019	Portion Pack Foods Limited	24HR Ration Packs Carton - Remote Area and out of hours catering, DFES - LGGGS Funded	- 1,919.50	BENMUNI	CSH
INV-PPF0805	10/12/2019	Portion Pack Foods Limited	24HR Ration Packs Carton - Remote Area and out of hours catering, DFES - LGGGS Funded	1,919.50	BENMUNI	INV
EFT27859	11/12/2019	MEANDA PARK MINIATURE ANIMAL PARK	GRANT FUNDED- Children's Day travelling animal farm at Community Garden	- 400.00	BENMUNI	CSH

SHIRE OF COLLIE**List of Accounts Submitted to Council - December 2019**

Chq/EFT	Date	Name	Description	Amount	Bank	Type
55	18/10/2019	MEANDA PARK MINIATURE ANIMAL PARK	GRANT FUNDED- Children's Day travelling animal farm at Community Garden	400.00	BENMUNI	INV
EFT27860	11/12/2019	South West Compressors	Service transfer station compressor Puma P15	-	1,230.13	BENMUNI CSH
00014086	07/11/2019	South West Compressors	Service depot compressor Westair SCR10, Service transfer station compressor Puma P15	1,230.13	BENMUNI	INV
EFT27861	11/12/2019	Tahnee Kelland	Mural painting at library entrance- FUNDED WITH GRANT MONEY	-	1,000.00	BENMUNI CSH
INV0034	15/09/2019	Tahnee Kelland	Mural painting at library entrance- FUNDED WITH GRANT MONEY	1,000.00	BENMUNI	INV
EFT27862	12/12/2019	WA Australian Services Union WA (ASU)	Payroll deductions	-	308.80	BENMUNI CSH
DEDUCTION	11/12/2019	WA Australian Services Union WA (ASU)			308.80	INV
EFT27863	12/12/2019	Department of Human Services	Payroll deductions	-	345.77	BENMUNI CSH
DEDUCTION	11/12/2019	Department of Human Services			345.77	INV
EFT27864	12/12/2019	Synergy	395602740 Lot 964 Wittenoon St Service Charge and Usage 15/10/2019 to 18/11/2019	-	34,734.28	BENMUNI CSH

SHIRE OF COLLIE

List of Accounts Submitted to Council - December 2019

Chq/EFT	Date	Name	Description	Amount	Bank	Type
3000124752	02/12/2019	Synergy	103912390 Lot U Coombes St Service Charge and Usage 11/09/2019 to 12/11/2019, , , , , 108754540 Loc 5263 Throssell St Service Charge and Usage 14/09/2019 to 13/11/2019, , , , , 136338480 86 Throssell St Service Charge and Usage 11/09/2019 to 12/11/2019, , , , , 212065320 Lot 1000 Davis St Service Charge and Usage 7/09/2019 to 8/11/2019, , , , , 218584750 130 Prinsep St Service Charge and Usage 4/09/2019 to 5/11/2019, , , , , 219603130 Medic St Service Charge and Usage 4/09/2019 to 5/11/2019, , , , , 230180590 Loc 23606 Cameron Rd Service Charge and Usage 14/09/2019 to 13/11/2019, , , , , 230180590 Loc 23606 Cameron Rd Service Charge and Usage 14/09/2019 to 13/11/2019, , , , , 246254110 Loc 19242 Lefroy St Service Charge and Usage 11/09/2019 to 12/11/2019, , , , , 254858780 8 Morrison way Service Charge and Usage 8/10/2019 to 5/11/2019, , , , , 283524910 Lot 1599 Moore St Service Charge and Usage 20/09/2019 to 19/11/2019, , , , , 290193420 59 Wittenoom St Service Charge and Usage 20/09/2019 to 21/11/2019, , , , , 395602740 Lot 964 Wittenoom St Service Charge and Usage 15/10/2019 to 18/11/2019, , , , , 446768030 Laurie St Service Charge and Usage 29/08/2019 to 29/10/2019, , , , , 455985420 Lot 5605 Ealing Rd Service Charge and Usage 11/09/2019 to 14/11/2019, , , , , 489294520 Loc 15195 U A Coombes St Service Charge and Usage 11/09/2019 to 12/11/2019, , , , , 514824540 15 Buckingham Way Service Charge and Usage 29/08/2019 to 29/10/2019, , , , , 542729470 Roberts St Service Charge	34,734.28	BENMUNI	INV
EFT27865	13/12/2019	Bunbury Machinery	Kubota Fertiliser Spreader - replacement pendulum for damaged item	-	446.13	BENMUNI CSH
H63838	04/10/2019	Bunbury Machinery	Kubota L5740DCA 4x4 57 HP Cab Tractor (CO30539) - replacement cab air con filter T1855-71600		86.50	BENMUNI INV
H63928	09/10/2019	Bunbury Machinery	Kubota Fertiliser Spreader - replacement pendulum for damaged item, Freight ex Melb		359.63	BENMUNI INV

SHIRE OF COLLIE**List of Accounts Submitted to Council - December 2019**

Chq/EFT	Date	Name	Description	Amount	Bank	Type
EFT27866	13/12/2019	Terry White Chemmart Collie Pharmacy	4 x 500ml Sunsense SPF50 Sunscreen	-	69.96	BENMUNI CSH
1941573	20/11/2019	Terry White Chemmart Collie Pharmacy	4 x 500ml Sunsense SPF50 Sunscreen		69.96	BENMUNI INV
EFT27867	13/12/2019	Statewide Bearings	2010 Mitsubishi Fuso Canter 4.0 LWB (CO11200) - tow hitch assembly to replace worn item (safety issue)	-	425.04	BENMUNI CSH
2491112	11/10/2019	Statewide Bearings	2010 Mitsubishi Fuso Canter 4.0 LWB (CO11200) - tow hitch assembly to replace worn item (safety issue)		425.04	BENMUNI INV
EFT27868	13/12/2019	Fairfax Media Publications Pty Limited (Collie Mail)	Collie Mail Advertising - Shire update for July, August, September, October, November, December.	-	1,398.06	BENMUNI CSH
0806994871	03/10/2019	Fairfax Media Publications Pty Limited (Collie Mail)	Collie Mail Advertising - Shire update for July, August, September, October, November, December.		444.00	BENMUNI INV
0806995072	03/10/2019	Fairfax Media Publications Pty Limited (Collie Mail)	Advert - Closure of Admin Building and Library - Collie Mail - 26th Sept and 3rd October 2019.		100.51	BENMUNI INV
0806994893	03/10/2019	Fairfax Media Publications Pty Limited (Collie Mail)	Collie Mail Bush Fire Awareness Feature		180.00	BENMUNI INV
0807021165	10/10/2019	Fairfax Media Publications Pty Limited (Collie Mail)	Public Notice-Advertising Commercial Bin Charges for 2019/20 in the Collie Mail		232.15	BENMUNI INV
0807044995	17/10/2019	Fairfax Media Publications Pty Limited (Collie Mail)	Advert - Notice of Special Council Meeting - Newly Elected Council Members - in the Public Notices section of the Collie Mail dated 17 October 2019.		141.65	BENMUNI INV
0807045009	17/10/2019	Fairfax Media Publications Pty Limited (Collie Mail)	Advertisement for Collie Mail - 17-10-19 - EOI		158.10	BENMUNI INV
0807102370	31/10/2019	Fairfax Media Publications Pty Limited (Collie Mail)	For advertising costs relating to RFQ 02/2019.		141.65	BENMUNI INV
EFT27869	13/12/2019	Collie Tyre & Exhaust Centre	Supply and fit drive tyres to replace worn tyres on 2010 Mitsubishi Fuso Canter 4.0 LWB (CO11200) 11R22.5 Hifly HH301 148/145M	-	2,760.00	BENMUNI CSH

SHIRE OF COLLIE

List of Accounts Submitted to Council - December 2019

Chq/EFT	Date	Name	Description	Amount	Bank	Type
00018653	15/11/2019	Collie Tyre & Exhaust Centre	Supply and fit drive tyres to replace worn tyres on 2010 Mitsubishi Fuso Canter 4.0 LWB (CO11200) 11R22.5 Hifly HH301 148/145M	2,760.00	BENMUNI	INV
EFT27870	13/12/2019	Cross Security Services	Please install CCTV to Library as per your quote dated 28/9/19	-	2,112.00	BENMUNI CSH
24829	13/11/2019	Cross Security Services	Please supply 20x new security swipe tags for Shire Administration Office.	242.00	BENMUNI	INV
24830	13/11/2019	Cross Security Services	Please install CCTV to Library as per your quote dated 28/9/19, Please install CCTV to Library as per your quote dated 28/9/19	1,870.00	BENMUNI	INV
EFT27871	13/12/2019	Chefmaster Australia	Carton of clear bin liners to suit 240ltr bins - 1600mmx710mmx400mm 75um (BL24075N)	-	278.50	BENMUNI CSH
00036707	17/10/2019	Chefmaster Australia	Carton of clear bin liners to suit 240ltr bins - 1600mmx710mmx400mm 75um (BL24075N)	278.50	BENMUNI	INV
EFT27872	13/12/2019	Clark Equipment Sales	2007 Bobcat S185H Skid Steere Loader (CO18857) - thermostat 6683004 for aircon repairs	-	330.00	BENMUNI CSH
08201429	18/11/2019	Clark Equipment Sales	2007 Bobcat S185H Skid Steere Loader (CO18857) - thermostat 6683004 for aircon repairs	330.00	BENMUNI	INV
EFT27873	13/12/2019	Dale Alcock Homes South West Pty Ltd	Kerb Bond Refund- Lot 100 (38) Annesley Drive Collie 2018061	-	500.00	BENMUNI CSH
KERBBOND REFUND	10/12/2019	Dale Alcock Homes South West Pty Ltd	Kerb Bond Refund- Lot 100 (38) Annesley Drive Collie 2018061,	500.00	BENMUNI	INV
EFT27874	13/12/2019	Department of Communities T/A Housing Authority	Withdrawal of Caveats on Telfer Crescent Lots 1812, 1813 and 1814.	-	274.14	BENMUNI CSH
200107156/SHIREOFCOLLIE	11/12/2019	Department of Communities T/A Housing Authority	Withdrawal of Caveats on Telfer Crescent Lots 1812, 1813 and 1814.	274.14	BENMUNI	INV
EFT27875	13/12/2019	Dale Hill-Power	Reimbursement of Recycled Christmas Lights	-	120.50	BENMUNI CSH
10122019	10/12/2019	Dale Hill-Power	Reimbursement of Recycled Christmas Lights	120.50	BENMUNI	INV
EFT27876	13/12/2019	Global Auto Electrical And Air Conditioning Services Pty Ltd	Inspect and repair air con fault in Caterpillar 428E2 Backhoe Loader (CO30051)	-	610.06	BENMUNI CSH

SHIRE OF COLLIE**List of Accounts Submitted to Council - December 2019**

Chq/EFT	Date	Name	Description	Amount	Bank	Type
00012858	18/11/2019	Global Auto Electrical And Air Conditioning Services Pty Ltd	Inspect and repair air con fault in Caterpillar 428E2 Backhoe Loader (CO30051)	610.06	BENMUNI	INV
EFT27877	13/12/2019	Joseph Northover	Consultation of Stage 4 River Walk from Minninup Pool to Lyons Park, negotiated total sum for observer for the Lyons Park section.	4,500.00	BENMUNI	CSH
JN028	10/10/2019	Joseph Northover	Consultation of Stage 4 River Walk from Minninup Pool to Lyons Park, negotiated total sum for observer for the Lyons Park section.	4,500.00	BENMUNI	INV
EFT27878	13/12/2019	Bucher Municipal	Side brooms (835-66) for Isuzu FSR 850 auto Road Sweeper VT651	473.66	BENMUNI	CSH
944320	23/09/2019	Bucher Municipal	Side brooms (835-66) for Isuzu FSR 850 auto Road Sweeper VT651	473.66	BENMUNI	INV
EFT27879	13/12/2019	Collie Mowers And More	Spark plugs for Kubota brush cutter repairs	23.40	BENMUNI	CSH
94802	13/11/2019	Collie Mowers And More	Spark plugs for Kubota brush cutter repairs	23.40	BENMUNI	INV
EFT27880	13/12/2019	Station Motors 1974	HOLDEN COLORADO LS 4X4 C/CAB (117CO) - supply and replace faulty drivers side seat belt assembly	1,087.32	BENMUNI	CSH
R37937	15/08/2019	Station Motors 1974	HOLDEN COLORADO LS 4X4 C/CAB (117CO) - supply and replace faulty drivers side seat belt assembly	454.78	BENMUNI	INV
20083	20/08/2019	Station Motors 1974	Holden Colorado Trailblazer (100CO) - oil and oil filters for service	111.08	BENMUNI	INV
20137	02/09/2019	Station Motors 1974	Holden Colorado Ute (109CO) - wiper blades, oil filters and oil for service	280.72	BENMUNI	INV
R38119	16/09/2019	Station Motors 1974	Rectify air-conditioning problem on Holden Colorado Ute (111CO)	120.00	BENMUNI	INV
20199	19/09/2019	Station Motors 1974	Sets of Leaf spring bushes for Holden Colorado 2015 LS Space Cab (112CO)	120.74	BENMUNI	INV
EFT27881	13/12/2019	Southern Cross Austereo Pty Ltd	Contribution to tourism broadcast from Central Park Friday 10 May 2019.	550.00	BENMUNI	CSH
70935553	31/10/2019	Southern Cross Austereo Pty Ltd	Contribution to tourism broadcast from Central Park Friday 10 May 2019.	550.00	BENMUNI	INV
EFT27882	13/12/2019	Smart Digital Australia	Portable Movie Screen for community events, funded by Lotterywest Grant	6,057.55	BENMUNI	CSH

SHIRE OF COLLIE**List of Accounts Submitted to Council - December 2019**

Chq/EFT	Date	Name	Description	Amount	Bank	Type
INV-0396	09/12/2019	Smart Digital Australia	Portable Movie Screen for community events, funded by Lotterywest Grant	6,057.55	BENMUNI	INV
EFT27883	13/12/2019	Winc Australia Pty Ltd	Library resources- tissues/PVA Glue/Dymo label tape/correction tape	-	417.21	BENMUNI CSH
9900842370	10/09/2019	Winc Australia Pty Ltd	Book tape / paper cups / office supplies.	134.32	BENMUNI	INV
9900860860	16/10/2019	Winc Australia Pty Ltd	Library resources- tissues/PVA Glue/Dymo label tape/correction tape	150.32	BENMUNI	INV
9900880755	22/11/2019	Winc Australia Pty Ltd	Library supplies- cutter blade replacement/file dividers/mouse pads	132.57	BENMUNI	INV
EFT27884	13/12/2019	T-Quip	Skid-bumper deck TOP112-1479	-	334.35	BENMUNI CSH
88394#5	19/11/2019	T-Quip	Parts to replace worn deck skids and rollers on Toro Groundsmaster 360 D/Cab 4wd with rear discharge cutting deck (CO30537) - shaft-roller TOP68-6840, Roller TOP68-6710, Nut-nyloc 1/2 inch UNC TOP3296-45, Roller TOP29-4820, Bolt 1/2 UNC x 4 TOP325-17	334.35	BENMUNI	INV
EFT27885	13/12/2019	Tyrepower	Mitsubishi Fuso FV51 Tip Truck (CO785) - supply and fit steer tyres (urgent)	-	1,190.00	BENMUNI CSH
3261306	10/10/2019	Tyrepower	Mercedes Benz Stirling 10T TipTruck (0075CO) - replace split tyre with supplied unit	60.00	BENMUNI	INV
3261477	10/10/2019	Tyrepower	2009 HINO 500 SERIES TIPPER TRUCK AUTO (CO19468) - repair damaged tyre	60.00	BENMUNI	INV
3262880	10/10/2019	Tyrepower	Mitsubishi Fuso FV51 Tip Truck (CO785) - supply and fit steer tyres (urgent)	1,070.00	BENMUNI	INV
EFT27886	13/12/2019	Toll Transport Pty Ltd	Freight Deliveries to Admin 11/11/2019 to 15/11/2019	-	233.31	BENMUNI CSH
0441-S280142	17/11/2019	Toll Transport Pty Ltd	Freight Deliveries to Depot 13/11/2019 to 16/11/2019 , , Freight Deliveries to Admin 11/11/2019 to 15/11/2019 ,	233.31	BENMUNI	INV
EFT27887	13/12/2019	Wet Deck Pools	Supply and Install 2 x Submersible Pit Pumps	-	1,292.45	BENMUNI CSH
INV-0806	10/10/2019	Wet Deck Pools	Repair 2 Hayward pumps	441.05	BENMUNI	INV
INV-0810	16/10/2019	Wet Deck Pools	Supply and Install 2 x Submersible Pit Pumps	851.40	BENMUNI	INV

SHIRE OF COLLIE**List of Accounts Submitted to Council - December 2019**

Chq/EFT	Date	Name	Description	Amount	Bank	Type
EFT27888	18/12/2019	Slee Anderson & Pidgeon Barristers & Solicitors	Provision of Formal Instrument of Agreement for builder works at 115 Throssell St, Collie	- 2,189.00	BENMUNI	CSH
2833	29/11/2019	Slee Anderson & Pidgeon Barristers & Solicitors	Provision of Formal Instrument of Agreement for builder works at 115 Throssell St, Collie	2,189.00	BENMUNI	INV
EFT27889	18/12/2019	Lindaz Central Deli	Meals for SES General Rescue Course - 2 days DFES - LGGS Funded	- 728.60	BENMUNI	CSH
00000380	09/11/2019	Lindaz Central Deli	Meals and Drinks for incident 458027,	252.20	BENMUNI	INV
00000381	27/11/2019	Lindaz Central Deli	Meals for SES General Rescue Course - 2 days, DFES - LGGS Funded	366.00	BENMUNI	INV
00000380	28/11/2019	Lindaz Central Deli	Milk Purchased for Admin November 2019 ,	110.40	BENMUNI	INV
EFT27890	18/12/2019	Arrow Bronze	Double niche wall plaque first inscription C279 mm X 121mm (with brackets) for KERRY TATE	- 480.59	BENMUNI	CSH
688459	29/11/2019	Arrow Bronze	Double niche wall plaque first inscription C279 mm X 121mm (with brackets) for KERRY TATE	480.59	BENMUNI	INV
EFT27891	18/12/2019	Air Liquide WA Pty Ltd	Monthly rental for gas cylinders in workshop - financial year 2019/2020 (Oxy G/Arcal/Oxy E/Acet E)	- 38.72	BENMUNI	CSH
WE1765	30/11/2019	Air Liquide WA Pty Ltd	Monthly rental for gas cylinders in workshop - financial year 2019/2020 (Oxy G/Arcal/Oxy E/Acet E)	38.72	BENMUNI	INV
EFT27892	18/12/2019	Access Wellbeing Services	EAP service	- 176.00	BENMUNI	CSH
22052	30/11/2019	Access Wellbeing Services	EAP service	176.00	BENMUNI	INV
EFT27893	18/12/2019	AMD Audit & Assurance Pty Ltd	Acquittal Audit of the Shire of Collie- Royalties for Regions Regional Community Services Fund- Collie River Revitalisation of the Year Ending 30 June 2019	- 385.00	BENMUNI	CSH
801674	30/11/2019	AMD Audit & Assurance Pty Ltd	Acquittal Audit of the Shire of Collie- Royalties for Regions Regional Community Services Fund- Collie River Revitalisation of the Year Ending 30 June 2019	385.00	BENMUNI	INV

SHIRE OF COLLIE**List of Accounts Submitted to Council - December 2019**

Chq/EFT	Date	Name	Description	Amount	Bank	Type
EFT27894	18/12/2019	Action Kerbing	Supply and lay flush kerb 160mm wide x 150mm deep, 30mm proud, for the River Walk Lions Park section	- 5,940.00	BENMUNI	CSH
INV-00001224	05/12/2019	Action Kerbing	Supply and lay flush kerb 160mm wide x 150mm deep, 30mm proud, for the River Walk Lions Park section	5,940.00	BENMUNI	INV
EFT27895	18/12/2019	AMALGAMATED CIVIL & PLANT HIRE PTY LTD	Supply gravel for the river walk path Mungalup Road	- 9,900.00	BENMUNI	CSH
00000061	29/11/2019	AMALGAMATED CIVIL & PLANT HIRE PTY LTD	Supply gravel for the river walk path Mungalup Road	9,900.00	BENMUNI	INV
EFT27896	18/12/2019	Ampac Debt Recovery (WA) Pty Ltd	Ampac Debt Recovery for Rates Period Ending 22/11/2019	- 3,464.06	BENMUNI	CSH
61187	28/11/2019	Ampac Debt Recovery (WA) Pty Ltd	Ampac Debt Recovery for Rates Period Ending 22/11/2019,	2,809.56	BENMUNI	INV
61331	30/11/2019	Ampac Debt Recovery (WA) Pty Ltd	Ampac Debt Recovery for Rates Period Ending 30/11/2019	44.00	BENMUNI	INV
61330	30/11/2019	Ampac Debt Recovery (WA) Pty Ltd	Ampac Debt Recovery for Rates Period Ending 30/11/2019	610.50	BENMUNI	INV
EFT27897	18/12/2019	Australasian Performing Right Association Limited T/A One Music	OneMusic Australia copyright music licence for Shire of Collie venues.	- 316.84	BENMUNI	CSH
016494	06/12/2019	Australasian Performing Right Association Limited T/A One Music	OneMusic Australia copyright music licence for Shire of Collie venues.	316.84	BENMUNI	INV
EFT27898	18/12/2019	Armac Stump Grinding	Removal of 6 marked dead trees on Harris River Rd, cut to ground level with all logs and debris removed.	- 4,400.00	BENMUNI	CSH
00002741	05/12/2019	Armac Stump Grinding	Removal of 6 marked dead trees on Harris River Rd, cut to ground level with all logs and debris removed.	4,400.00	BENMUNI	INV
EFT27899	18/12/2019	BELL FIRE EQUIPMENT	DRAEGER PS5000 Standard Unit with lung demand valve as per quote 529/1 (08/19) amended.	- 4,906.00	BENMUNI	CSH
INV-1700	26/09/2019	BELL FIRE EQUIPMENT	DRAEGER PS5000 Standard Unit with lung demand valve as per quote 529/1 (08/19) amended., Carbon fibre SCBA 6.8Lt air cylinder/300 bar, Person distress alarm, Freight (estimated)	4,906.00	BENMUNI	INV

SHIRE OF COLLIE

List of Accounts Submitted to Council - December 2019

Chq/EFT	Date	Name	Description	Amount	Bank	Type
EFT27900	18/12/2019	Bunnings Building Supplies	Xmas lights for installation in Central Park	-	757.78	BENMUNI CSH
2706/01335772	05/12/2019	Bunnings Building Supplies	Xmas lights for installation in Central Park		757.78	BENMUNI INV
EFT27901	18/12/2019	Bunbury Harvey Regional Council	Regional Waste Education Program - September 2019	-	3,161.23	BENMUNI CSH
54113	30/09/2019	Bunbury Harvey Regional Council	Regional Waste Education Program - September 2019 ,		1,392.05	BENMUNI INV
54118	30/09/2019	Bunbury Harvey Regional Council	Hook Bin Hire - September 2019 ,		188.56	BENMUNI INV
54689	30/11/2019	Bunbury Harvey Regional Council	Regional Waste Education Program - November 2019 ,		1,392.05	BENMUNI INV
54690	30/11/2019	Bunbury Harvey Regional Council	Hook Bin Hire - November 2019,		188.57	BENMUNI INV
EFT27902	18/12/2019	Bosch Timber Floors	Roche Park Cleaning 2 x 5L BONA Floor Cleaner - BOFLOCHLECON05	-	217.80	BENMUNI CSH
SOF6332-1	02/12/2019	Bosch Timber Floors	Roche Park Cleaning , 2 x 5L BONA Floor Cleaner - BOFLOCHLECON05, 1 x 5L BONA Deep Clean Solution - BOFLODEECLE		217.80	BENMUNI INV
EFT27903	18/12/2019	Scott Christinger	Please repair TV antenna plug/cable at 43 Elouera Street, Collie. Please arrange access with Jackie Stocks at Elders Real Estate.	-	215.00	BENMUNI CSH
22877	26/11/2019	Scott Christinger	Please repair TV antenna plug/cable at 43 Elouera Street, Collie. Please arrange access with Jackie Stocks at Elders Real Estate.		215.00	BENMUNI INV
EFT27904	18/12/2019	Statewide Bearings	Wire loop pins for workshop stock	-	71.50	BENMUNI CSH
2491464	25/11/2019	Statewide Bearings	1 x Alternator belt for CO783		22.00	BENMUNI INV
2491492	27/11/2019	Statewide Bearings	Wire loop pins for workshop stock		27.50	BENMUNI INV
2491504	28/11/2019	Statewide Bearings	Sealed bearings for Peruzzo Panther 1800 High Lift Mower repairs		22.00	BENMUNI INV
EFT27905	18/12/2019	Collie Cheerio Club	Contribution to 2019 Collie Cheerio Club Annual Pensioners Christmas party.	-	1,000.00	BENMUNI CSH
2019012	03/12/2019	Collie Cheerio Club	Contribution to 2019 Collie Cheerio Club Annual Pensioners Christmas party.		1,000.00	BENMUNI INV
EFT27906	18/12/2019	Pete's	Hi vis work shirts with logo for employee #541	-	601.60	BENMUNI CSH
219869	05/11/2019	Pete's	Hi vis work shirts with logo for employee #541, Work pants for employee #541		436.00	BENMUNI INV

SHIRE OF COLLIE**List of Accounts Submitted to Council - December 2019**

Chq/EFT	Date	Name	Description	Amount	Bank	Type
220507	27/11/2019	Pete's	Sewing of WA Ranger badges and name on shirts	27.60	BENMUNI	INV
220689	03/12/2019	Pete's	Pairs of work jeans to replace damaged items for employee #532	138.00	BENMUNI	INV
EFT27907	18/12/2019	Cleanaway	Waste Refuse Contract November 2019	-	26,437.12	BENMUNI CSH
21554108	30/11/2019	Cleanaway	Recycling Contract November 2019	1,618.57	BENMUNI	INV
21556830	30/11/2019	Cleanaway	Waste Refuse Contract November 2019 , , Recycling Contract November 2019 , , Organics Contract November 2019	24,818.55	BENMUNI	INV
EFT27908	18/12/2019	BOC Limited	Monthly rental for medical oxygen bottle (size C) at swimming pool for period 1/7/19 to 30/6/20.	-	5.90	BENMUNI CSH
4024216101	28/11/2019	BOC Limited	Monthly rental for medical oxygen bottle (size C) at swimming pool for period 1/7/19 to 30/6/20.	5.90	BENMUNI	INV
EFT27909	18/12/2019	Collie Senior Citizens Inc	Refund of Over Payment on Synergy Bill for Collie Seniors Citizens	-	284.47	BENMUNI CSH
28112019	28/11/2019	Collie Senior Citizens Inc	Refund of Over Payment on Synergy Bill for Collie Seniors Citizens	284.47	BENMUNI	INV
EFT27910	18/12/2019	Collie Electrical Service	Disconnect and reconnect power at Wallsend ground to enable tree pruning	-	99.00	BENMUNI CSH
00010368	05/12/2019	Collie Electrical Service	Disconnect and reconnect power at Wallsend ground to enable tree pruning	99.00	BENMUNI	INV
EFT27911	18/12/2019	Cross Security Services	Alarm system monitoring 1-10-19 to 31/12/19 Admin	-	1,600.00	BENMUNI CSH

SHIRE OF COLLIE

List of Accounts Submitted to Council - December 2019

Chq/EFT	Date	Name	Description	Amount	Bank	Type
24965	29/11/2019	Cross Security Services	Alarm system monitoring 1-10-19 to 31/12/19 Admin, Alarm system monitoring 1-10-19 to 31/12/19 Library, Alarm system monitoring 1-10-19 to 31/12/19 Roche Park, Alarm system monitoring 1-10-19 to 31/12/19 Swimming Pool, Alarm system monitoring 1-10-19 to 31/12/19 Visitors Centre, Alarm system monitoring 1-10-19 to 31/12/19 Transfer Station (pro rata), Alarm system monitoring 1-10-19 to 31/12/19 Works Depot (pro rata), Alarm system monitoring 1-10-19 to 31/12/19 Pound (pro rata)	1,600.00	BENMUNI	INV
EFT27912	18/12/2019	Schweppes Australia Pty Ltd	Roche Park Kiosk - Drinks order 2 x 750ml water 1 x 375ml Pepsi Max & Pepsi 1 x Berry Gatorade	- 184.65	BENMUNI	CSH
0809214585	28/11/2019	Schweppes Australia Pty Ltd	Roche Park Kiosk - Drinks order, 2 x 750ml water, 1 x 375ml Pepsi Max & Pepsi, 1 x Berry Gatorade	184.65	BENMUNI	INV
EFT27913	18/12/2019	Central Garage	CEO Jeep 102CO - 110,000km service.	- 398.20	BENMUNI	CSH
00012516	15/10/2019	Central Garage	CEO Jeep 102CO - 110,000km service.	398.20	BENMUNI	INV
EFT27914	18/12/2019	Drycleaners On Steere	Maintenance of Council Chambers - Drycleaning - October to December 2019	- 49.50	BENMUNI	CSH
7980	04/12/2019	Drycleaners On Steere	Maintenance of Council Chambers - Drycleaning - October to December 2019	49.50	BENMUNI	INV
EFT27915	18/12/2019	Craven Foods	Roche Park Kiosk - Confectionery	- 286.43	BENMUNI	CSH
4619123	28/11/2019	Craven Foods	Roche Park Kiosk - Confectionery, Roche Park Cleaning - Hand towels, bin bags	200.25	BENMUNI	INV
4620200	05/12/2019	Craven Foods	Roche Park Cleaning - 4 x Polycotton Mopheads, Roche Park Kiosk - Confectionery	86.18	BENMUNI	INV
EFT27916	18/12/2019	Collie Roof Plumbing	Please carry out cleaning of gutters at Shire Depot - to include main workshop, large rear open storage shed and dog pound.	- 451.00	BENMUNI	CSH

SHIRE OF COLLIE

List of Accounts Submitted to Council - December 2019

Chq/EFT	Date	Name	Description	Amount	Bank	Type
218	25/11/2019	Collie Roof Plumbing	Please carry out cleaning of gutters at Shire Depot - to include main workshop, large rear open storage shed and dog pound.	451.00	BENMUNI	INV
EFT27917	18/12/2019	Connor Watts	Junior Basketball Umpiring at Roche Park	-	160.00	BENMUNI CSH
17122019	17/12/2019	Connor Watts	Junior Basketball Umpiring at Roche Park		160.00	BENMUNI INV
EFT27918	18/12/2019	Canvas Works South West	Remove, repair and refit Shade Sails at Lions Park	-	1,575.00	BENMUNI CSH
00005449	06/12/2019	Canvas Works South West	Remove, repair and refit Shade Sails at Lions Park		750.00	BENMUNI INV
00005449	06/12/2019	Canvas Works South West	Replace elastic rope on TRAILER 8 X 5 ROCKER (1TIR794) cover, Replace elastic rope on 8x5 Rocker Trailer (CO16431) cover		242.00	BENMUNI INV
00005449	06/12/2019	Canvas Works South West	Length of rope elastic for tarp cover on CSTMAC BJT-TIPPER (1TRH588)		143.00	BENMUNI INV
00005449	06/12/2019	Canvas Works South West	Repair foam base on seat in 2009 HINO 500 SERIES TIPPER TRUCK AUTO (CO19468) and manufacture new seat cover		440.00	BENMUNI INV
EFT27919	18/12/2019	Landgate	Gross Rental Valuations Chargeable Schedule No:G 2019/19 Dated 19/10/2019 to 01/11/2019	-	135.70	BENMUNI CSH
352820-10000927	27/11/2019	Landgate	Gross Rental Valuations Chargeable Schedule No:G 2019/19, Dated 19/10/2019 to 01/11/2019		67.85	BENMUNI INV
352840-10000927	28/11/2019	Landgate	Rural UV'S Chargeable Schedule NO; R 2019/10 Dated 02/10/2019 to 08/11/2019 Rural UV'S Chargeable Schedule NO; M 2019/8 Dated 04/10/2019 to 05/11/2019,		67.85	BENMUNI INV
EFT27920	18/12/2019	Domino's Collie - Phoenix Pizza Pty Ltd	8 Pizzas and delivery - DFES Pre Season Forum and Training, 15 attendees DFES - LGGS Funded	-	45.00	BENMUNI CSH
17	25/11/2019	Domino's Collie - Phoenix Pizza Pty Ltd	8 Pizzas and delivery - DFES Pre Season Forum and Training, 15 attendees, DFES - LGGS Funded		45.00	BENMUNI INV
EFT27921	18/12/2019	TJ Depiazzi	30m3 soil conditioner to be delivered to Lions Park River Walk construction 06/12	-	876.92	BENMUNI CSH

SHIRE OF COLLIE**List of Accounts Submitted to Council - December 2019**

Chq/EFT	Date	Name	Description	Amount	Bank	Type
104159	06/12/2019	TJ Depiazzi	30m3 soil conditioner to be delivered to Lions Park River Walk construction 06/12	876.92	BENMUNI	INV
EFT27922	18/12/2019	Down To Earth Training & Assessing	2 day chemical training course - Parks and Gardens and Works	-	3,044.50	BENMUNI CSH
00030486	29/11/2019	Down To Earth Training & Assessing	2 day chemical training course - Parks and Gardens and Works	-	3,044.50	BENMUNI INV
EFT27923	18/12/2019	Dynamic Security Management P/L	Alaram Call Out to Pound/Depot 30/11/2019	-	330.00	BENMUNI CSH
0003	02/12/2019	Dynamic Security Management P/L	Alaram Call Out to Pound/Depot 30/11/2019,	-	330.00	BENMUNI INV
EFT27924	18/12/2019	Frontline Fire And Rescue	64921, 66830, 67085, 63412, 66849, BR9 White Helmet Complete - Heather O'Connor, Brett Rosel, Shannon Proudfoot, John Mattaboni, Rob Rusconi. DFES - LGGS Funded	-	208.89	BENMUNI CSH
66048	27/11/2019	Frontline Fire And Rescue	64921, 66830, 67085, 63412, 66849, BR9 White Helmet Complete - Heather O'Connor, Brett Rosel, Shannon Proudfoot, John Mattaboni, Rob Rusconi., DFES - LGGS Funded	-	208.89	BENMUNI INV
EFT27925	18/12/2019	Global Auto Electrical And Air Conditioning Services Pty Ltd	Remove panels etc, remove blocked condensor and re-assemble on Caterpillar 428E2 Backhoe Loader (CO30051)	-	1,280.70	BENMUNI CSH
00012857	29/11/2019	Global Auto Electrical And Air Conditioning Services Pty Ltd	Remove panels etc, remove blocked condensor and re-assemble on Caterpillar 428E2 Backhoe Loader (CO30051)	-	532.95	BENMUNI INV
00012856	29/11/2019	Global Auto Electrical And Air Conditioning Services Pty Ltd	Rectify air con issue and service unit on Mercedes Benz Stirling 10T TipTruck (0075CO) (safety issue)	-	485.12	BENMUNI INV
00012888	03/12/2019	Global Auto Electrical And Air Conditioning Services Pty Ltd	Repair lights and reverse alarm issue on AMMANN ROLLER (CO14145)	-	262.63	BENMUNI INV
EFT27926	18/12/2019	Greenbatch Foundation	Greenbatch attendance with Waste Education Stand at the Collie Show for plastic recycling demonstration.	-	531.00	BENMUNI CSH
INV-0213	24/11/2019	Greenbatch Foundation	Greenbatch attendance with Waste Education Stand at the Collie Show for plastic recycling demonstration.	-	531.00	BENMUNI INV

SHIRE OF COLLIE**List of Accounts Submitted to Council - December 2019**

Chq/EFT	Date	Name	Description	Amount	Bank	Type
EFT27927	18/12/2019	Grace Records Management Aust Pty Ltd	Destruction of 49 Archive boxes	-	724.02	BENMUNI CSH
RY00942891	30/11/2019	Grace Records Management Aust Pty Ltd	Destruction of 49 Archive boxes, Collection Fee		373.20	BENMUNI INV
RY00942891	30/11/2019	Grace Records Management Aust Pty Ltd	100 x C3 Small Archive Cartons + Delivery		350.82	BENMUNI INV
EFT27928	18/12/2019	Henderson Hardware	2 x Oates Dura-Clean Roller/wringer buckets	-	151.50	BENMUNI CSH
00022651	20/11/2019	Henderson Hardware	2 x Oates Dura-Clean Roller/wringer buckets		120.00	BENMUNI INV
00023792	05/12/2019	Henderson Hardware	Please cut x7 keys @ \$4.50ea		31.50	BENMUNI INV
EFT27929	18/12/2019	INLINE RENOVATIONS	Please carry out repair/replacement of damaged boards to Court 3 at Roche Park as per your quote #2286. To be carried out Monday 2/12 and Tuesday 3/12 - please complete by 3pm Tues to allow for court activities.	-	4,751.00	BENMUNI CSH
00002291	05/12/2019	INLINE RENOVATIONS	Please carry out repair/replacement of damaged boards to Court 3 at Roche Park as per your quote #2286. To be carried out Monday 2/12 and Tuesday 3/12 - please complete by 3pm Tues to allow for court activities.		4,751.00	BENMUNI INV
EFT27930	18/12/2019	It Vision	Dog Registration Renewal Template	-	1,100.00	BENMUNI CSH
32229	30/09/2019	It Vision	Dog Registration Renewal Template, CatRegistration Renewal Template		1,100.00	BENMUNI INV
EFT27931	18/12/2019	Ian Guppy & Co Smash Repairs	Windscreen fitting and reseal	-	715.48	BENMUNI CSH
62908	05/12/2019	Ian Guppy & Co Smash Repairs	Windscreen for Isuzu FRR500M Tipper - Drains Truck (CO30614), Front windscreen rubber, Windscreen sealer, Windscreen fitting and reseal		715.48	BENMUNI INV
EFT27932	18/12/2019	Interphone	Interphone NBN Optic Fibre Internet 1400 MBPS 1tb Access Charges 01/11/19 - 30/11/19	-	130.90	BENMUNI CSH

SHIRE OF COLLIE

List of Accounts Submitted to Council - December 2019

Chq/EFT	Date	Name	Description	Amount	Bank	Type
1213960-17	18/12/2019	Interphone	Interphone NBN Optic Fibre Internet 1400 MBPS 1tb Access Charges 01/11/19 - 30/11/19 ,	130.90	BENMUNI	INV
EFT27933	18/12/2019	South West Isuzu	Repairs to Isuzu FSR 850 auto Road Sweeper VT651 as per diagnosis. Replace accelerator relays and main switching relay. Replace faulty immobiliser control unit. Test and check operation.	- 1,462.65	BENMUNI	CSH
842570	28/11/2019	South West Isuzu	Repairs to Isuzu FSR 850 auto Road Sweeper VT651 as per diagnosis. Replace accelerator relays and main switching relay. Replace faulty immobiliser control unit. Test and check operation.	997.91	BENMUNI	INV
842549	28/11/2019	South West Isuzu	Diagnose and report engine fault code on Isuzu FSR 850 auto Road Sweeper VT651	464.74	BENMUNI	INV
EFT27934	18/12/2019	Jack Rinder	Junior Basketball Umpiring at Roche Park	- 120.00	BENMUNI	CSH
17122019	17/12/2019	Jack Rinder	Junior Basketball Umpiring at Roche Park ,	120.00	BENMUNI	INV
EFT27935	18/12/2019	Lotex Filter Cleaning Service	Clean filters	- 352.47	BENMUNI	CSH
00005197	06/11/2019	Lotex Filter Cleaning Service	Clean filters	126.20	BENMUNI	INV
00005218	20/11/2019	Lotex Filter Cleaning Service	Clean filters	226.27	BENMUNI	INV
EFT27936	18/12/2019	Living Springs	Water Cooler Annual Rental - 01/12/19 - 30/11/19	- 418.00	BENMUNI	CSH
INV-6957	30/09/2019	Living Springs	15 ltr Bottle Springwater - Admin	99.00	BENMUNI	INV
INV-7250	30/11/2019	Living Springs	15 ltr Bottles Spring Water , , Water Cooler Annual Rental - 01/12/19 - 30/11/19	319.00	BENMUNI	INV
EFT27937	18/12/2019	Lyons Airconditioning Services WA Pty Ltd	2005 Caterpillar 953C WDA Track Loader (CO17046) - supply replacement gasket and steel guard for gasket	- 38.50	BENMUNI	CSH
149354	29/11/2019	Lyons Airconditioning Services WA Pty Ltd	2005 Caterpillar 953C WDA Track Loader (CO17046) - supply replacement gasket and steel guard for gasket	38.50	BENMUNI	INV
EFT27938	18/12/2019	McLeods Barristers & Solicitors	Planning Legal Advice- McMahon W Bush Fire Act Prosecution 6 York Street	- 1,313.63	BENMUNI	CSH
111410	29/11/2019	McLeods Barristers & Solicitors	Planning Legal Advice- McMahon W Bush Fire Act Prosecution 6 York Street	1,313.63	BENMUNI	INV

SHIRE OF COLLIE**List of Accounts Submitted to Council - December 2019**

Chq/EFT	Date	Name	Description	Amount	Bank	Type
EFT27939	18/12/2019	Marketforce	Advert - West Australian - Annual Electors Meeting - Mon 25 November 2019 in the Local Govt. Notices section.	- 1,721.24	BENMUNI	CSH
32730	01/11/2019	Marketforce	Early Settlement Discount For Invoice 29655 September 2019	- 40.08	BENMUNI	INV
30758	26/11/2019	Marketforce	Advert - West Australian - Annual Electors Meeting - Mon 25 November 2019 in the Local Govt. Notices section.	1,002.54	BENMUNI	INV
30757	26/11/2019	Marketforce	Advert - Disposal of Property - West Australian - Friday 22 November 2019 in the Local Govt. Section.	758.78	BENMUNI	INV
EFT27940	18/12/2019	Ixom Operations Pty Ltd	Service fee for 70kg and 920kg chlorine cyclinders at pool- Open Order for twelve Months and Billed Monthly at \$6.35 per day November	- 209.55	BENMUNI	CSH
6185306	30/11/2019	Ixom Operations Pty Ltd	Service fee for 70kg and 920kg chlorine cyclinders at pool- Open Order for twelve Months and Billed Monthly at \$6.35 per day November	209.55	BENMUNI	INV
EFT27941	18/12/2019	Our Community Garden Collie	Small Community Grant to Purchase Materials and Enable Construction of Compost Beds	- 1,955.00	BENMUNI	CSH
7	25/11/2019	Our Community Garden Collie	Small Community Grant to Purchase Materials and Enable Construction of Compost Beds	1,955.00	BENMUNI	INV
EFT27942	18/12/2019	O.C.P Sales Communication Products	2x Portable Radio's	- 1,974.28	BENMUNI	CSH
00051153	28/11/2019	O.C.P Sales Communication Products	2x Portable Radio's	1,974.28	BENMUNI	INV
EFT27943	18/12/2019	Opteon Property Consultants	Market rental valuation for Collie River Valley Tourist Park.	- 4,000.00	BENMUNI	CSH
9968937-1	20/11/2019	Opteon Property Consultants	Market rental valuation for Collie River Valley Tourist Park.	4,000.00	BENMUNI	INV
EFT27944	18/12/2019	Pilatti Bros Transport	3.0m3 20/14 concrete for River Walk construction Mungalup/Crampton St intersection 05/12	- 943.36	BENMUNI	CSH

SHIRE OF COLLIE**List of Accounts Submitted to Council - December 2019**

Chq/EFT	Date	Name	Description	Amount	Bank	Type
INV-2473	05/12/2019	Pilatti Bros Transport	3.0m3 20/14 concrete for River Walk construction Mungalup/Crampton St intersection 05/12	943.36	BENMUNI	INV
EFT27945	18/12/2019	Pak-it Computers	1 x HP 62 Printer Cartridge Black XL, 1 x HP 62 Printer Cartridge Colour XL	-	135.00	BENMUNI CSH
A6053	13/12/2019	Pak-it Computers	1 x HP 62 Printer Cartridge Black XL, 1 x HP 62 Printer Cartridge Colour XL	-	135.00	BENMUNI INV
EFT27946	18/12/2019	Picton Civil Pty	Hire of Cat 320 Excavator and Operator for River Walk Construction 11th,12th and 13th of November Mob and Demob	-	4,273.50	BENMUNI CSH
P11451	25/11/2019	Picton Civil Pty	Hire of Cat 320 Excavator and Operator for River Walk Construction 11th,12th and 13th of November, Mob and Demob	-	4,273.50	BENMUNI INV
EFT27947	18/12/2019	PFI Supplies	For provision of cleaning supplies per your quote #2649 dated 27/11/19.	-	1,436.50	BENMUNI CSH
15457	26/11/2019	PFI Supplies	4 x boxes of toilet paper 3 ply code 6012E, 2 x rolls Bin Liners LTR240-30B, 2 x Rolls Bin Liners LTR120-25B	-	338.20	BENMUNI INV
15455	26/11/2019	PFI Supplies	Please provide soap dispenser as per 15/11/19 email for \$69.90.	-	69.90	BENMUNI INV
15453	26/11/2019	PFI Supplies	Please supply and deliver 2x Sanitary Bins (charcoal) at \$69.90ea as per R. Locke's 11/11/19 email.	-	139.80	BENMUNI INV
15513	27/11/2019	PFI Supplies	For provision of cleaning supplies per your quote #2649 dated 27/11/19.	-	612.60	BENMUNI INV
15544	28/11/2019	PFI Supplies	6x boxes of Slimfold Hand Towels (re-order code C-HT0183) as discussed with Rae.	-	276.00	BENMUNI INV
EFT27948	18/12/2019	Position Partners	Supply Replacement Survey Equipment: GT-503 3 Second Robotic Total Station, RC-5 Remote Control for Series, and FC-5000 Geo Cell With Cradle.	-	37,587.00	BENMUNI CSH
PSI-274484	15/11/2019	Position Partners	Supply Replacement Survey Equipment:, GT-503 3 Second Robotic Total Station,, RC-5 Remote Control for Series, and, FC-5000 Geo Cell With Cradle.	-	37,587.00	BENMUNI INV

SHIRE OF COLLIE**List of Accounts Submitted to Council - December 2019**

Chq/EFT	Date	Name	Description	Amount	Bank	Type
EFT27949	18/12/2019	Purewater Pool Services Pty Ltd	Annual pre season service of Aquarius dosing unit at Water Park	- 2,353.45	BENMUNI	CSH
2066	27/11/2019	Purewater Pool Services Pty Ltd	Annual pre season service of Aquarius dosing unit at Water Park	2,353.45	BENMUNI	INV
EFT27950	18/12/2019	Suez Recycling & Recovery (Perth) Pty Ltd	Recycling Contract for November 2019	- 4,591.18	BENMUNI	CSH
34936536	30/11/2019	Suez Recycling & Recovery (Perth) Pty Ltd	Recycling Contract for November 2019,	4,591.18	BENMUNI	INV
EFT27951	18/12/2019	Reuben's Newsagency	Newspapers and delivery charges for Library October to November 2019	- 223.34	BENMUNI	CSH
01122019	01/12/2019	Reuben's Newsagency	Newspapers and delivery charges for Admin November 2019 ,	66.00	BENMUNI	INV
01122019	01/12/2019	Reuben's Newsagency	Newspapers and delivery charges for Library October to November 2019 ,	157.34	BENMUNI	INV
EFT27952	18/12/2019	COLLIE RIDGE MOTEL	Supply catering for Business Connections event 4 December 2019 of antipasto platters plus hot finger food.	- 1,047.00	BENMUNI	CSH
196014	04/12/2019	COLLIE RIDGE MOTEL	Hire of Function Room for Business Connections event 4 December 2019. (Theatre style setup), Hire of Media Package for Business Connections event 4 December 2019. (lectern, microphone, projector & screen plus white board), Supply Tea/Coffee for Business Connections event 4 December 2019 setup in room., Supply catering for Business Connections event 4 December 2019 of antipasto platters plus hot finger food., Supply refreshments for Business Connections event 4 December 2019. (Wine, Beer, Cider and Softdrinks)	1,047.00	BENMUNI	INV
EFT27953	18/12/2019	Reece Pilatti	INDOOR HOCKEY UMPIRING AT ROCHE PARK	- 120.00	BENMUNI	CSH
12122019	12/12/2019	Reece Pilatti	INDOOR HOCKEY UMPIRING AT ROCHE PARK,	120.00	BENMUNI	INV

SHIRE OF COLLIE

List of Accounts Submitted to Council - December 2019

Chq/EFT	Date	Name	Description	Amount	Bank	Type
EFT27954	18/12/2019	Sheridan's	2 x Name Badges - Chief Bush Fire Control Officer and Fire Control Officer as per Shire of Collie template with new logo.	- 98.34	BENMUNI	CSH
78824	25/11/2019	Sheridan's	2 x Name Badges - Chief Bush Fire Control Officer and Fire Control Officer as per Shire of Collie template with new logo.	98.34	BENMUNI	INV
EFT27955	18/12/2019	South West Compressors	Inspect and diagnose fan overload warning on workshop compressor. Supply new fan motor to replace faulty unit.	- 935.88	BENMUNI	CSH
00014173	28/11/2019	South West Compressors	Inspect and diagnose fan overload warning on workshop compressor. Supply new fan motor to replace faulty unit.	935.88	BENMUNI	INV
EFT27956	18/12/2019	Southern Lock & Security	40mm Red #003 Emergency Services access locks and keys DFES - LGGS Funded	- 400.62	BENMUNI	CSH
B12246	10/12/2019	Southern Lock & Security	40mm Red #003 Emergency Services access locks and keys, DFES - LGGS Funded	400.62	BENMUNI	INV
EFT27957	18/12/2019	Station Motors 1974	75,000 service for Holden Captiva rego 107-CO. Please also check exhaust filter. Refer to Scott Geere at Shire pf: 0409 857 777.	- 918.28	BENMUNI	CSH
R37474	06/06/2019	Station Motors 1974	75,000 service for Holden Captiva rego 107-CO. Please also check exhaust filter. Refer to Scott Geere at Shire pf: 0409 857 777.	463.50	BENMUNI	INV
R37861	05/08/2019	Station Motors 1974	Director Development Services Vehicle service 150,000km	454.78	BENMUNI	INV
EFT27958	18/12/2019	Stewart & Heaton Clothing Co Pty Ltd	J795-GLD, T781-GLD + Badges as per order forms - Collie Preston BFB 1 Member Full Kit DFES - LGGS Funded	- 35.28	BENMUNI	CSH
SIN-3134813	28/11/2019	Stewart & Heaton Clothing Co Pty Ltd	J795-GLD, T781-GLD + Badges as per order forms - Collie Preston BFB 1 Member Full Kit, DFES - LGGS Funded	6.84	BENMUNI	INV
SIN-3134773	28/11/2019	Stewart & Heaton Clothing Co Pty Ltd	J795-GLD, T781-GLD + Badges as per order forms - Collieburn Cardiff BFB 1 Member Full Kit, DFES - LGGS Funded	6.84	BENMUNI	INV
SIN-3135349	29/11/2019	Stewart & Heaton Clothing Co Pty Ltd	J795-GLD, T781-GLD + Badges as per order forms - Collie Preston BFB 1 Member Full Kit, DFES - LGGS Funded	10.80	BENMUNI	INV

SHIRE OF COLLIE**List of Accounts Submitted to Council - December 2019**

Chq/EFT	Date	Name	Description	Amount	Bank	Type
SIN-3135461	29/11/2019	Stewart & Heaton Clothing Co Pty Ltd	J795-GLD, T781-GLD + Badges as per order forms - Collieburn Cardiff BFB 1 Member Full Kit, DFES - LGGS Funded	10.80	BENMUNI	INV
EFT27959	18/12/2019	South West Fire Units	Worslet Light Tanker B Service DFES - LGGS Funded	-	3,407.47	BENMUNI CSH
I32942	26/11/2019	South West Fire Units	Worslet Light Tanker B Service, DFES - LGGS Funded	3,407.47	BENMUNI	INV
EFT27960	18/12/2019	SPURLING ENGINEERING	Supply 1 golden yellow powder coated bollard, 1200mm high x 165mm dia, with cap	-	291.50	BENMUNI CSH
00011996	30/11/2019	SPURLING ENGINEERING	Supply 1 golden yellow powder coated bollard, 1200mm high x 165mm dia, with cap	291.50	BENMUNI	INV
EFT27961	18/12/2019	South West Group Of Affiliated Agricultural Associations Inc	Shire of Collie contribution to audio visual equipment for promotion at 2019 Royal Show pavilion.	-	700.00	BENMUNI CSH
00236	25/11/2019	South West Group Of Affiliated Agricultural Associations Inc	Shire of Collie contribution to audio visual equipment for promotion at 2019 Royal Show pavilion.	700.00	BENMUNI	INV
EFT27962	18/12/2019	Southwest Oil Supplies	1000L pod of AdBlue for workshop stock, includes delivery to depot	-	880.00	BENMUNI CSH
00004094	02/12/2019	Southwest Oil Supplies	1000L pod of AdBlue for workshop stock, includes delivery to depot	880.00	BENMUNI	INV
EFT27963	18/12/2019	T-Quip	Solid front castor wheel (grey) for Peruzzo Panther 1800 High Lift Mower	-	513.65	BENMUNI CSH
88529#12	25/11/2019	T-Quip	Solid front castor wheel (grey) for Peruzzo Panther 1800 High Lift Mower	380.15	BENMUNI	INV
88637#5	27/11/2019	T-Quip	Parts to replace worn deck skids and rollers on Toro Groundsmaster 360 D/Cab 4wd with rear discharge cutting deck (CO30537) - shaft-roller TOP68-6840, Roller TOP68- 6710, Nut-nyloc 1/2 inch UNC TOP3296-45, Roller TOP29- 4820, Bolt 1/2 UNC x 4 TOP325-17	133.50	BENMUNI	INV
EFT27964	18/12/2019	TRUE TRACK TRUCK ALIGNING	Wheel alignment for Mitsubishi Fuso FV51 Tip Truck (CO785)	-	220.00	BENMUNI CSH

SHIRE OF COLLIE

List of Accounts Submitted to Council - December 2019

Chq/EFT	Date	Name	Description	Amount	Bank	Type
26562	04/11/2019	TRUE TRACK TRUCK ALIGNING	Wheel alignment for Mitsubishi Fuso FV51 Tip Truck (CO785)	220.00	BENMUNI	INV
EFT27965	18/12/2019	Tyrepower	Wheel alignment for Holden Colorado 4x4 CR/Cab CHAS LX 2.8l (108CO)	-	BENMUNI	CSH
3265988	28/11/2019	Tyrepower	Wheel alignment for Holden Colorado 4x4 CR/Cab CHAS LX 2.8l (108CO)	120.00	BENMUNI	INV
EFT27966	18/12/2019	TBS Rural & Hardware	Boxes of I-25 adjustable gear drive sprinklers for reticulation repairs - stock	-	BENMUNI	CSH
OEI89667	26/11/2019	TBS Rural & Hardware	Boxes of I-25 adjustable gear drive sprinklers for reticulation repairs - stock	1,452.00	BENMUNI	INV
OEI89669	27/11/2019	TBS Rural & Hardware	1 Drum Of Hydrochloric Acid	58.00	BENMUNI	INV
OEI89675	29/11/2019	TBS Rural & Hardware	7/90/30 Hinge joint wire for path realignment on River Walk at Lions Park, 72m roll of 2.5mm tie wire	361.00	BENMUNI	INV
OEI89673	29/11/2019	TBS Rural & Hardware	6 Bottles of Just Musk Disinfectant,	150.00	BENMUNI	INV
EFT27968	18/12/2019	The Colliefields	Cheese/Grazing Platters for Business Connections Event - 4 July 2019 - Business Hub Launch Energise Collie	-	BENMUNI	CSH
199	15/12/2019	The Colliefields	Cheese/Grazing Platters for Business Connections Event - 4 July 2019 - Business Hub Launch Energise Collie	228.00	BENMUNI	INV
EFT27969	18/12/2019	Terresa Briggs	Reimbursement of Metafit Music and Choreography June to December 2019	-	BENMUNI	CSH
01122019	01/12/2019	Terresa Briggs	Reimbursement of Metafit Music and Choreography June to December 2019 ,	107.70	BENMUNI	INV
EFT27970	18/12/2019	The Plant Supply Co	Telopea speciosissima for Central Park / Water Playground	-	BENMUNI	CSH
54302	18/10/2019	The Plant Supply Co	Telopea speciosissima for Central Park / Water Playground, Delivery to Shire Depot	874.50	BENMUNI	INV
54501	31/10/2019	The Plant Supply Co	Plants (mesembryanthemum - white & orange) for landscaping Worsley and Cardiff Bushfire Brigade Buildings, Delivery to depot	407.00	BENMUNI	INV
EFT27971	18/12/2019	Trisley's Hydraulic Services	Supply and install 5 Ratemeter to Toddlers Pool Quoted Price \$2350"	-	BENMUNI	CSH

SHIRE OF COLLIE**List of Accounts Submitted to Council - December 2019**

Chq/EFT	Date	Name	Description	Amount	Bank	Type
100203071	29/11/2019	Trisley's Hydraulic Services	Supply and install 5 Ratemeter to Toddlers Pool Quoted Price \$2350"	2,394.79	BENMUNI	INV
EFT27972	18/12/2019	Toll Transport Pty Ltd	Freight Deliveries to Depot 18/11/2019 to 22/11/2019 -	128.32	BENMUNI	CSH
0442-S280142	24/11/2019	Toll Transport Pty Ltd	Freight Deliveries to Depot 18/11/2019 to 22/11/2019 , , Freight Deliveries to Admin 18/11/2019 to 22/11/2019 ,	128.32	BENMUNI	INV
EFT27973	18/12/2019	VEENS DESIGN DRAFTING SERVICE	Detailed design drawings for community facility at Collie Mineworkers Memorial Swimming Pool. -	13,900.75	BENMUNI	CSH
24253	29/11/2019	VEENS DESIGN DRAFTING SERVICE	Detailed design drawings for community facility at Collie Mineworkers Memorial Swimming Pool.	3,000.00	BENMUNI	INV
24428	18/12/2019	VEENS DESIGN DRAFTING SERVICE	Detailed design drawings for community facility at Collie Mineworkers Memorial Swimming Pool.	10,900.75	BENMUNI	INV
EFT27974	18/12/2019	Print Sync Business Solutions	SES Photocopier Charges 26/10/2019 to 25/11/2019 -	191.75	BENMUNI	CSH
WA00465533	29/11/2019	Print Sync Business Solutions	SES Photocopier Charges 26/10/2019 to 25/11/2019 ,	191.75	BENMUNI	INV
EFT27975	18/12/2019	White Building Co Pty Ltd	Design & Construction of Cardiff Bushfire Brigade Buildings as per tender award. -	25,850.90	BENMUNI	CSH
00012396	29/11/2019	White Building Co Pty Ltd	Design & Construction of Cardiff Bushfire Brigade Buildings as per tender award.	16,169.47	BENMUNI	INV
00012397	29/11/2019	White Building Co Pty Ltd	Design & Construction of Worsley Bushfire Brigade Building as per Tender award.	9,681.43	BENMUNI	INV
EFT27976	18/12/2019	Collie Bin Hire	Supply and empty skip bins at Minninup Pool, Black Diamond and Shire Depot, Financial year 2019/20 -	968.00	BENMUNI	CSH
7341	31/07/2019	Collie Bin Hire	Supply and empty skip bins at Minninup Pool, Black Diamond and Shire Depot, Financial year 2019/20	308.00	BENMUNI	INV
7443	30/09/2019	Collie Bin Hire	Supply and empty skip bins at Minninup Pool, Black Diamond and Shire Depot, Financial year 2019/20	308.00	BENMUNI	INV

SHIRE OF COLLIE**List of Accounts Submitted to Council - December 2019**

Chq/EFT	Date	Name	Description	Amount	Bank	Type
7564	30/11/2019	Collie Bin Hire	Supply and empty skip bins at Minninup Pool, Black Diamond and Shire Depot, Financial year 2019/20	352.00	BENMUNI	INV
EFT27977	18/12/2019	Western Australian Electoral Commission	2019 Local Government Election Costs	-	30,916.27	BENMUNI CSH
3130	02/12/2019	Western Australian Electoral Commission	2019 Local Government Election Costs		30,916.27	BENMUNI INV
EFT27978	18/12/2019	The West Australian Newspapers Ltd	Advert in the SW Times - 14th & 21st November for an Environmental Health Officer in the Positions vacant section.	-	1,021.70	BENMUNI CSH
1025012620191130	30/11/2019	The West Australian Newspapers Ltd	Advert in the SW Times - 14th & 21st November for an Environmental Health Officer in the Positions vacant section.		790.40	BENMUNI INV
1025012620191130	30/11/2019	The West Australian Newspapers Ltd	Advertising of RFQ 02/2019 - Southwest Times.		231.30	BENMUNI INV
EFT27979	18/12/2019	WA TREASURY CORPORATION	Principal Loan 117 Repayment	-	52,791.80	BENMUNI CSH
30092019	30/09/2019	WA TREASURY CORPORATION	Principal Loan 117 Repayment, , Interest on Loan 117,		52,791.80	BENMUNI INV
EFT27980	18/12/2019	West Oz Wildlife	GRANT FUNDING- West Oz Wildlife educational library visit with travel costs.	-	357.50	BENMUNI CSH
2078	03/12/2019	West Oz Wildlife	GRANT FUNDING- West Oz Wildlife educational library visit with travel costs.		357.50	BENMUNI INV
EFT27981	18/12/2019	Whitney Marley	INDOOR HOCKEY UMPIRING AT ROCHE PARK	-	105.00	BENMUNI CSH
12122019	12/12/2019	Whitney Marley	INDOOR HOCKEY UMPIRING AT ROCHE PARK,		105.00	BENMUNI INV
EFT27982	18/12/2019	Telstra	Telstra - Account 0509899000 Internet Usage to 01/12/2019 Service and Equipment Rental to 01/01/2020	-	5,579.29	BENMUNI CSH

SHIRE OF COLLIE**List of Accounts Submitted to Council - December 2019**

Chq/EFT	Date	Name	Description	Amount	Bank	Type
0108	06/12/2019	Water Corporation	Water Account 9006805679 Sports Ground Montgomery St Allanson Usage and Service Charges 01/11/19 to 31/12/19	58.33	BENMUNI	INV
EFT27984	19/12/2019	G V KLEM PLANNING AND PROJECT MANAGEMENT	Planning and Project Management - Contract, Completion and Acquittal of Collie Motorplex Upgrade Stage 2	- 1,457.00	BENMUNI	CSH
0237	17/12/2019	G V KLEM PLANNING AND PROJECT MANAGEMENT	Planning and Project Management - Contract, Completion and Acquittal of Collie Motorplex Upgrade Stage 2	1,457.00	BENMUNI	INV
EFT27985	19/12/2019	Outdoor World Bunbury	Construction of Re-use shop shed includes leanto as per quote 5514 as received.	- 14,125.00	BENMUNI	CSH
00004355	11/12/2019	Outdoor World Bunbury	Construction of Re-use shop shed includes leanto as per quote 5514 as received.	14,125.00	BENMUNI	INV
EFT27986	19/12/2019	P & S Griggs Plumbing	Please locate water leak at the Margareta Wilson Centre. Metre is spinning when no one in attendance.	- 2,750.83	BENMUNI	CSH
4948	30/10/2019	P & S Griggs Plumbing	Please locate water leak at the Margareta Wilson Centre. Metre is spinning when no one in attendance.	709.13	BENMUNI	INV
4949	30/10/2019	P & S Griggs Plumbing	Please locate water leak at the Margareta Wilson Centre. Metre is spinning when no one in attendance.	451.00	BENMUNI	INV
4950	30/10/2019	P & S Griggs Plumbing	Please locate water leak at the Margareta Wilson Centre. Metre is spinning when no one in attendance.	1,590.70	BENMUNI	INV
EFT27987	19/12/2019	Civil & Structural Engineers	Please carry out onsite inspection at 115 Throssell Street, Collie to determine full design/certification scope. Note the Shire will facilitate invasive inspection.	- 3,740.00	BENMUNI	CSH
9539187	13/11/2019	Civil & Structural Engineers	Please carry out onsite inspection at 115 Throssell Street, Collie to determine full design/certification scope. Note the Shire will facilitate invasive inspection.	3,740.00	BENMUNI	INV
EFT27988	19/12/2019	Collie River Valley Medical Centre	Incident AOD test	- 99.00	BENMUNI	CSH
439828DD1	07/10/2019	Collie River Valley Medical Centre	Incident AOD test	49.50	BENMUNI	INV

SHIRE OF COLLIE**List of Accounts Submitted to Council - December 2019**

Chq/EFT	Date	Name	Description	Amount	Bank	Type
440308CC2	09/10/2019	Collie River Valley Medical Centre	D & A Test - Bushfire Volunteer Incident - # 84052 - 9 October 2019	49.50	BENMUNI	INV
EFT27989	20/12/2019	Synergy	Account 102659550 Street lighting 01/11/19 to 02/12/19	-	17,343.18	BENMUNI CSH
2012825457	02/12/2019	Synergy	Account 102659550 Street lighting 01/11/19 to 02/12/19,	-	17,210.34	BENMUNI INV
2024824740	02/12/2019	Synergy	Electricity Account 190579390 Period Ending 26/11/2019 ,	-	132.84	BENMUNI INV
EFT27990	20/12/2019	WA Australian Services Union WA (ASU)	Payroll deductions	-	308.80	BENMUNI CSH
DEDUCTION	25/12/2019	WA Australian Services Union WA (ASU)			308.80	INV
EFT27991	20/12/2019	Department of Human Services	Payroll deductions	-	345.77	BENMUNI CSH
DEDUCTION	25/12/2019	Department of Human Services			345.77	INV
EFT27992	23/12/2019	Brighthouse	Stage 2 - community engagement, demand analysis and prefeasability for Minniup Pool	-	8,168.60	BENMUNI CSH
INV-862	08/12/2019	Brighthouse	Stage 2 - community engagement, demand analysis and prefeasability for Minniup Pool	-	8,168.60	BENMUNI INV
41701	06/12/2019	Department Of Transport	CRV Number Plates 048CO Coalfields Museum and Historical Research Centre	-	200.00	BENMUNI CSH
CRV PLATES 048CO	27/11/2019	Department Of Transport	CRV Number Plates 048CO Coalfields Museum and Historical Research Centre	-	200.00	BENMUNI INV
41702	06/12/2019	Greg's Pharmacy	3 tubs of sunscreen	-	89.97	BENMUNI CSH
323204	18/11/2019	Greg's Pharmacy	3 tubs of sunscreen	-	89.97	BENMUNI INV
41703	06/12/2019	Shire Of Collie - Petty Cash	Gift Cards for Departing Employees	-	265.23	BENMUNI CSH

SHIRE OF COLLIE

List of Accounts Submitted to Council - December 2019

Chq/EFT	Date	Name	Description	Amount	Bank	Type
PETTY CASH JUNE TO NOVEMBER	27/11/2019	Shire Of Collie - Petty Cash	Timber Window Mouldings for Window Repairs at Swimming Pool, 3 PKTS Screws for Door Repairs- Soliders Park, Dyna Bolts for Installing DEFIB Cabinet- Pool, Fuel for 106CO- Fuel Card Wasn't Available, Ice for Pitch Angels, Ribbon for Opening of Pedestrians Bridge at the Collie Motorplex, Sparkling Water for Motorplex Bridge Opening, Bread Rolls, Gift Cards for Departing Employees, Food for Meeting, Certificate Paper and Certificate Holders, Modify Survey Data Sim Card to Fit Micro Sim	265.23	BENMUNI	INV
41704	06/12/2019	Pamela True	Reimbursement of Over Paid Infringement	-	170.00	BENMUNI CSH
18112019	18/11/2019	Pamela True	Reimbursement of Over Paid Infringement	-	170.00	BENMUNI INV
41705	10/12/2019	AMP FLEXIBLE LIFETIME SUPERANNUATION	Superannuation contributions	-	201.49	BENMUNI CSH
SUPER	18/09/2019	AMP FLEXIBLE LIFETIME SUPERANNUATION			201.49	BENMUNI INV
41706	13/12/2019	Garrick John Gulvin	Winner of 2019/20 Win Back Your Rates	-	1,000.00	BENMUNI CSH
11122019	11/12/2019	Garrick John Gulvin	Winner of 2019/20 Win Back Your Rates,	-	1,000.00	BENMUNI INV
41707	18/12/2019	Roche Park Recreation Centre	Fruit for Kiosk	-	121.20	BENMUNI CSH
PETTYCASH OCTOBER/NOVEMBER	30/11/2019	Roche Park Recreation Centre	Milk for Kiosk at Roche Park, Tea for Kiosk at Roche Park, Ice Cube Bags for 1st Aid, Wing Nuts and Hex Heads for Soccer Goals, Laundry Basket, Fruit for Kiosk, Fruit for Kiosk, Crisps for Kiosk, Tic Tacs for GF Xmas Wishes, Stickers for Sportytots, Stickers for Sportytots, Ice Cub Bags 1st Aid		121.20	BENMUNI INV
41708	18/12/2019	State Emergency Service	Supplies for Training Exercise	-	552.70	BENMUNI CSH
SES PETTY CASH OCTOBER	31/10/2019	State Emergency Service	LPG 8.5 Swap Gas Bottle, Supplies for Training Exercise, Cool Drink for Training, Bins and Cleaning for SES Shed		382.30	BENMUNI INV

SHIRE OF COLLIE

List of Accounts Submitted to Council - December 2019

Chq/EFT	Date	Name	Description	Amount	Bank	Type
SES PETTY CASH NOVEMBER	30/11/2019	State Emergency Service	Beikin HDMi Cable Comms Room, Meals for incident 460278, Food and Drink for BGR Course 30th November and 1st December 2019, Food and Drink for BGR Course 30th November and 1st December 2019	170.40	BENMUNI	INV
DD25427.1	21/12/2019	Caltex Australia	Litres of diesel	-	16,662.85	BENMUNI CSH
9423211477	06/11/2019	Caltex Australia	Litres of diesel		4,306.93	BENMUNI INV
9423264748	20/11/2019	Caltex Australia	Litres of diesel		3,403.57	BENMUNI INV
9423243234	13/11/2019	Caltex Australia	Litres of diesel		4,721.65	BENMUNI INV
9423308656	27/11/2019	Caltex Australia	Litres of diesel		4,230.70	BENMUNI INV
DD25427.2	06/12/2019	Wright Express Australia PTY LTD	Wex Motorpass November 2019 Fuel and Card Fees CO31241	-	1,048.19	BENMUNI CSH
FUEL NOVEMBER	22/11/2019	Wright Express Australia PTY LTD	Wex Motorpass November 2019 Fuel and Card Fees 1EFB204 , , Wex Motorpass November 2019 Fuel and Card Fees 1BNF241 , , Wex Motorpass November 2019 Fuel and Card Fees 1EZE593 , , Wex Motorpass November 2019 Fuel and Card Fees 1EOB212 , , Wex Motorpass November 2019 Fuel and Card Fees CO31241 , , Wex Motorpass November 2019 Fuel and Card Fees 1DCF765 , , Wex Motorpass November 2019 Fuel and Card Fees 1DAN765 , , Wex Motorpass November 2019 Fuel and Card Fees 1CXV789 , , Wex Motorpass November 2019 Fuel and Card Fees C017526 , , Wex Motorpass November 2019 Fuel and Card Fees 1CST499 , , Wex Motorpass November 2019 Fuel and Card Fees C017526 ,		1,048.19	BENMUNI INV
DD25427.3	21/12/2019	Caltex Energy Wa	Star Card Fuel November 2019 100CO	-	1,785.44	BENMUNI CSH

SHIRE OF COLLIE**List of Accounts Submitted to Council - December 2019**

Chq/EFT	Date	Name	Description	Amount	Bank	Type
0107353106	30/11/2019	Caltex Energy Wa	Star Card Fuel November 2019 102CO , , Star Card Fuel November 2019 100CO , , Star Card Fuel November 2019 104CO , , Star Card Fuel November 2019 105CO , , Star Card Fuel November 2019 106CO , , Star Card Fuel November 2019 WorkShop ,	1,785.44	BENMUNI	INV
DD25429.1	16/12/2019	Coles Supermarket (retail Decisions Pty Ltd)	Roche Park Kiosk - Chocolates, crisps, milk	-	573.12	BENMUNI CSH
9896	15/11/2019	Coles Supermarket (retail Decisions Pty Ltd)	Washing Powder for PPE, DFES - LGGS Funded, Drinks to replace Brigade Stock used on DFES Training Courses, DFES - LGGS Funded		96.66	BENMUNI INV
8929	14/11/2019	Coles Supermarket (retail Decisions Pty Ltd)	Supplies for Seniors Week Event		27.65	BENMUNI INV
6154	28/11/2019	Coles Supermarket (retail Decisions Pty Ltd)	Roche Park Kiosk Purchases - Pies, sausage rolls, pasties, sugar, crisps, cheese		66.00	BENMUNI INV
871	13/11/2019	Coles Supermarket (retail Decisions Pty Ltd)	Roche Park Cleaning - Toilet discs, Fly spray, Roche Park Kiosk - Icy poles, serviettes, cheese, Roche Park Move Your Body Expenses - Milk, coffee, tea, sugar		95.78	BENMUNI INV
7296	04/11/2019	Coles Supermarket (retail Decisions Pty Ltd)	Tea, Coffee, Tissues and Serviettes		63.86	BENMUNI INV
247	12/11/2019	Coles Supermarket (retail Decisions Pty Ltd)	Restock Chambers with Diet Coke, Ginger Beer, Mik, Lemon Lime & Bitters, AAA Batteries, Toilet Paper, 3 x Toilet Brush Sets, 2 x Pkts Biscuits OH&S Meeting		101.65	BENMUNI INV
3446	06/11/2019	Coles Supermarket (retail Decisions Pty Ltd)	Roche Park Kiosk - Crisps, Sausage Rolls		22.40	BENMUNI INV
6815	11/11/2019	Coles Supermarket (retail Decisions Pty Ltd)	Roche Park Kiosk - Milk, Cheese, Sausage Rolls		18.45	BENMUNI INV
3226	20/11/2019	Coles Supermarket (retail Decisions Pty Ltd)	Roche Park Cleaning - Toilet discs, Roche Park Program Expenses - Junior Basketball 2 x Chocolates for Jnr coaches, Roche Park Kiosk - Chocolates, crisps, milk		80.67	BENMUNI INV
DD25438.2	20/12/2019	NAVMAN WIRELESS AUSTRALIA PTY LTD	GPS Tracking Lease Payment 15.11.019 to 14.12.2019	-	1,182.50	BENMUNI CSH

SHIRE OF COLLIE

List of Accounts Submitted to Council - December 2019

Chq/EFT	Date	Name	Description	Amount	Bank	Type
91820976	15/11/2019	NAVMAN WIRELESS AUSTRALIA PTY LTD	GPS Tracking Lease Payment 15.11.019 to 14.12.2019 ,	1,182.50	BENMUNI	INV
DD25438.3	01/12/2019	Les Mills Asia Pacific	Contract Fee Bodypump, Bodybalance and RPM 01/11/2019 to 30/11/2019	- 594.47	BENMUNI	CSH
1030907	01/11/2019	Les Mills Asia Pacific	Contract Fee Bodypump, Bodybalance and RPM 01/11/2019 to 30/11/2019 ,	594.47	BENMUNI	INV
DD25438.4	15/12/2019	SG FLEET AUSTRALIA PTY LTD	Community Emergency Services Vehicle Lease Rental 05/12/2019 to 04/01/2020 Registration CO31241 and 918830	- 2,038.21	BENMUNI	CSH
AUSG00216885	30/11/2019	SG FLEET AUSTRALIA PTY LTD	Community Emergency Services Vehicle Lease Rental 05/12/2019 to 04/01/2020 Registration CO31241 and 918830 ,	2,038.21	BENMUNI	INV
DD25453.1	11/12/2019	WA SUPER	Payroll deductions	- 22,055.63	BENMUNI	CSH
SUPER	11/12/2019	WA SUPER		19,184.23	BENMUNI	INV
DEDUCTION	11/12/2019	WA SUPER		353.72	BENMUNI	INV
DEDUCTION	11/12/2019	WA SUPER		1,671.07	BENMUNI	INV
DEDUCTION	11/12/2019	WA SUPER		20.00	BENMUNI	INV
DEDUCTION	11/12/2019	WA SUPER		115.94	BENMUNI	INV
DEDUCTION	11/12/2019	WA SUPER		233.00	BENMUNI	INV
DEDUCTION	11/12/2019	WA SUPER		100.00	BENMUNI	INV
DEDUCTION	11/12/2019	WA SUPER		377.67	BENMUNI	INV
DD25453.2	11/12/2019	REST PERSONAL DIVISION	Superannuation contributions	- 242.20	BENMUNI	CSH
SUPER	11/12/2019	REST PERSONAL DIVISION		242.20	BENMUNI	INV
DD25453.3	11/12/2019	AMP SUPERANNUATION SAVINGS TRUST	Superannuation contributions	- 468.19	BENMUNI	CSH
SUPER	11/12/2019	AMP SUPERANNUATION SAVINGS TRUST		468.19	BENMUNI	INV
DD25453.4	11/12/2019	ESSENTIAL SUPERANNUATION	Superannuation contributions	- 216.21	BENMUNI	CSH
SUPER	11/12/2019	ESSENTIAL SUPERANNUATION		216.21	BENMUNI	INV
DD25453.5	11/12/2019	ANZ SMART CHOICE SUPER	Payroll deductions	- 430.41	BENMUNI	CSH
SUPER	11/12/2019	ANZ SMART CHOICE SUPER		332.59	BENMUNI	INV
DEDUCTION	11/12/2019	ANZ SMART CHOICE SUPER		97.82	BENMUNI	INV
DD25453.6	11/12/2019	NETWEALTH SUPERANNUATION MASTER FUND	Superannuation contributions	- 237.44	BENMUNI	CSH
SUPER	11/12/2019	NETWEALTH SUPERANNUATION MASTER FUND		237.44	BENMUNI	INV

SHIRE OF COLLIE

List of Accounts Submitted to Council - December 2019

Chq/EFT	Date	Name	Description	Amount	Bank	Type
DD25453.7	11/12/2019	COLONIAL FIRST STATE-FIRST CHOICE SUPERANNUATION TRUST	Superannuation contributions	-	516.22	BENMUNI CSH
SUPER	11/12/2019	COLONIAL FIRST STATE-FIRST CHOICE SUPERANNUATION TRUST			516.22	BENMUNI INV
DD25453.8	11/12/2019	Mercer Super Trust- Personal Supn DIV	Payroll deductions	-	644.32	BENMUNI CSH
SUPER	11/12/2019	Mercer Super Trust- Personal Supn DIV			483.24	BENMUNI INV
DEDUCTION	11/12/2019	Mercer Super Trust- Personal Supn DIV			161.08	BENMUNI INV
DD25453.9	11/12/2019	AUSTRALIAN SUPER	Superannuation contributions	-	4,345.62	BENMUNI CSH
SUPER	11/12/2019	AUSTRALIAN SUPER			3,004.71	BENMUNI INV
DEDUCTION	11/12/2019	AUSTRALIAN SUPER			500.00	BENMUNI INV
DEDUCTION	11/12/2019	AUSTRALIAN SUPER			628.04	BENMUNI INV
SUPER	11/12/2019	AUSTRALIAN SUPER			69.29	BENMUNI INV
SUPER	11/12/2019	AUSTRALIAN SUPER			73.03	BENMUNI INV
SUPER	11/12/2019	AUSTRALIAN SUPER			70.55	BENMUNI INV
DD25456.1	14/12/2019	APPLE PTY LTD	Workplace inspections - i-auditor 12 month membership	-	17.99	BENMUNI CSH
MX97DXM0Q4	28/11/2019	APPLE PTY LTD	Workplace inspections - i-auditor 12 month membership,		17.99	BENMUNI INV
DD25456.2	14/12/2019	SAI GLOBAL LIMITED	Provision of AS 4906 small works contract	-	256.82	BENMUNI CSH
SAIG1IS-995786	21/11/2019	SAI GLOBAL LIMITED	Provision of AS 4906 small works contract		139.59	BENMUNI INV
SAIG1IS-995796	21/11/2019	SAI GLOBAL LIMITED	Provision of AS 4906 small works contract		117.23	BENMUNI INV
DD25456.3	14/12/2019	MASTER BUILDERS ASSOCIATION OF WA	Provision of 2x copies of MBWA Commercial Medium Works contract	-	107.00	BENMUNI CSH
INV-15045	14/11/2019	MASTER BUILDERS ASSOCIATION OF WA	Provision of 2x copies of MBWA Commercial Medium Works contract		107.00	BENMUNI INV
DD25456.4	14/12/2019	Bendigo Bank Credit Card	Credit Card Fees 01/11/2019 to 30/11/2019	-	4.00	BENMUNI CSH
30112019	30/11/2019	Bendigo Bank Credit Card	Credit Card Fees 01/11/2019 to 30/11/2019		4.00	BENMUNI INV
DD25456.5	14/12/2019	The Royal Life Saving Society Of WA	Maurice Dhue reaccreditation Pool Lifeguard 10/11/2019 at Bilgoman Sun 10th 9:00am - 3:00pm	-	159.00	BENMUNI CSH
WEB-150622	01/11/2019	The Royal Life Saving Society Of WA	Maurice Dhue reaccreditation Pool Lifeguard , 10/11/2019 at Bilgoman, Sun 10th 9:00am - 3:00pm		159.00	BENMUNI INV
DD25456.6	14/12/2019	Project Tools	Task Managment Software	-	128.00	BENMUNI CSH
181022864	06/11/2019	Project Tools	Task Managment Software		128.00	BENMUNI INV

SHIRE OF COLLIE**List of Accounts Submitted to Council - December 2019**

Chq/EFT	Date	Name	Description	Amount	Bank	Type
DD25456.7	14/12/2019	WESTIN PERTH	Accommodation and Parking to attend PIA Award - Check In Friday 8 November and Departing Saturday 9 November 2019 - DDS Mr Andrew Dover	- 279.13	BENMUNI	CSH
1641157	08/11/2019	WESTIN PERTH	Accommodation and Parking to attend PIA Award - Check In Friday 8 November and Departing Saturday 9 November 2019 - DDS Mr Andrew Dover	279.13	BENMUNI	INV
DD25456.8	14/12/2019	MILLS WILSON (EVENTBRITE TICKETING)	Festival & Event Management Masterclass for Community Development Officer & Event Officer	- 500.00	BENMUNI	CSH
2415-9272-3851-5273	11/11/2019	MILLS WILSON (EVENTBRITE TICKETING)	Festival & Event Management Masterclass for Community Development Officer & Event Officer	500.00	BENMUNI	INV
DD25456.9	14/12/2019	Bunnings Building Supplies	Tables for Seniors Morning Tea event	- 236.00	BENMUNI	CSH
2706/99803337	15/11/2019	Bunnings Building Supplies	Tables for Seniors Morning Tea event	236.00	BENMUNI	INV
DD25474.1	25/12/2019	WA SUPER	Superannuation contributions	- 21,557.92	BENMUNI	CSH
SUPER	25/12/2019	WA SUPER		18,521.86	BENMUNI	INV
SUPER	25/12/2019	WA SUPER		133.26	BENMUNI	INV
DEDUCTION	25/12/2019	WA SUPER		329.40	BENMUNI	INV
DEDUCTION	25/12/2019	WA SUPER		1,641.38	BENMUNI	INV
DEDUCTION	25/12/2019	WA SUPER		20.00	BENMUNI	INV
DEDUCTION	25/12/2019	WA SUPER		118.83	BENMUNI	INV
DEDUCTION	25/12/2019	WA SUPER		233.00	BENMUNI	INV
DEDUCTION	25/12/2019	WA SUPER		100.00	BENMUNI	INV
DEDUCTION	25/12/2019	WA SUPER		377.67	BENMUNI	INV
SUPER	25/12/2019	WA SUPER		82.52	BENMUNI	INV
DD25474.2	25/12/2019	AMP FLEXIBLE LIFETIME SUPERANNUATION	Superannuation contributions	- 214.60	BENMUNI	CSH
SUPER	25/12/2019	AMP FLEXIBLE LIFETIME SUPERANNUATION		214.60	BENMUNI	INV
DD25474.3	25/12/2019	REST PERSONAL DIVISION	Superannuation contributions	- 344.11	BENMUNI	CSH
SUPER	25/12/2019	REST PERSONAL DIVISION		344.11	BENMUNI	INV
DD25474.4	25/12/2019	AMP SUPERANNUATION SAVINGS TRUST	Superannuation contributions	- 470.52	BENMUNI	CSH

SHIRE OF COLLIE

List of Accounts Submitted to Council - December 2019

Chq/EFT	Date	Name	Description	Amount	Bank	Type
SUPER	25/12/2019	AMP SUPERANNUATION SAVINGS TRUST		470.52	BENMUNI	INV
DD25474.5	25/12/2019	ESSENTIAL SUPERANNUATION	Superannuation contributions	-	221.69	BENMUNI CSH
SUPER	25/12/2019	ESSENTIAL SUPERANNUATION		221.69	BENMUNI	INV
DD25474.6	25/12/2019	ANZ SMART CHOICE SUPER	Payroll deductions	-	430.41	BENMUNI CSH
SUPER	25/12/2019	ANZ SMART CHOICE SUPER		332.59	BENMUNI	INV
DEDUCTION	25/12/2019	ANZ SMART CHOICE SUPER		97.82	BENMUNI	INV
DD25474.7	25/12/2019	NETWEALTH SUPERANNUATION MASTER FUND	Superannuation contributions	-	233.13	BENMUNI CSH
SUPER	25/12/2019	NETWEALTH SUPERANNUATION MASTER FUND		233.13	BENMUNI	INV
DD25474.8	25/12/2019	COLONIAL FIRST STATE-FIRST CHOICE SUPERANNUATION TRUST	Superannuation contributions	-	423.64	BENMUNI CSH
SUPER	25/12/2019	COLONIAL FIRST STATE-FIRST CHOICE SUPERANNUATION TRUST		423.64	BENMUNI	INV
DD25474.9	25/12/2019	Mercer Super Trust- Personal Supn DIV	Payroll deductions	-	644.32	BENMUNI CSH
SUPER	25/12/2019	Mercer Super Trust- Personal Supn DIV		483.24	BENMUNI	INV
DEDUCTION	25/12/2019	Mercer Super Trust- Personal Supn DIV		161.08	BENMUNI	INV
DD25503.1	21/12/2019	iinet Connect Better	NBN25 Satellite 150 Collie Harris River Brigade Monthly Charge Period of 21/12/2019 to 21/01/2020	-	156.54	BENMUNI CSH
115989435	07/12/2019	iinet Connect Better	NBN25 Satellite 150 Collie Preston Brigade Monthly Charge Period of 21/12/2019 to 21/01/2020, , NBN25 Satellite 150 Collie Allanson Brigade Monthly Charge Period of 21/12/2019 to 21/01/2020, , NBN25 Satellite 150 Collie Harris River Brigade Monthly Charge Period of 21/12/2019 to 21/01/2020,		156.54	BENMUNI INV
DD25512.2	27/12/2019	8 Thai Ladies	CEO's Department - Lunch	-	54.50	BENMUNI CSH
20122019	20/12/2019	8 Thai Ladies	CEO's Department - Lunch		54.50	BENMUNI INV
DD25535.1	15/12/2019	Fleet Partners Pty Ltd	Fleet Partners Lease of Ford Kuga DLP5 15/11/2019 to 14/12/2019	-	752.53	BENMUNI CSH
LASH04722003A	01/12/2019	Fleet Partners Pty Ltd	Fleet Partners Lease of Ford Kuga DLP5 15/11/2019 to 14/12/2019 ,		752.53	BENMUNI INV
DD25453.10	11/12/2019	CONSTRUCTION & BUILDING INDUSTRY SUPER	Superannuation contributions	-	194.19	BENMUNI CSH

SHIRE OF COLLIE**List of Accounts Submitted to Council - December 2019**

Chq/EFT	Date	Name	Description	Amount	Bank	Type
SUPER	11/12/2019	CONSTRUCTION & BUILDING INDUSTRY SUPER		194.19	BENMUNI	INV
DD25453.11	11/12/2019	COMMONWEALTH BANK OF AUST	Superannuation contributions	-	89.54	BENMUNI CSH
SUPER	11/12/2019	COMMONWEALTH BANK OF AUST		89.54	BENMUNI	INV
DD25453.12	11/12/2019	MTAA SUPERANNUATION FUND	Superannuation contributions	-	217.44	BENMUNI CSH
SUPER	11/12/2019	MTAA SUPERANNUATION FUND		217.44	BENMUNI	INV
DD25453.13	11/12/2019	AMP FLEXIBLE LIFETIME SUPERANNUATION	Superannuation contributions	-	223.49	BENMUNI CSH
SUPER	11/12/2019	AMP FLEXIBLE LIFETIME SUPERANNUATION		223.49	BENMUNI	INV
DD25456.10	14/12/2019	Skycomp Technology (K&L Group Pty Ltd)	Panasonic Toughbook CF-54 Mk3 with 4G DFES - LGGS Approved overspend	-	2,690.00	BENMUNI CSH
1000051819	12/11/2019	Skycomp Technology (K&L Group Pty Ltd)	Panasonic Toughbook CF-54 Mk3 with 4G, DFES - LGGS Approved overspend		2,690.00	BENMUNI INV
DD25456.11	14/12/2019	Microsoft Regional Sales PTE LTD	Microsoft Office Software License Update 11/11/2019 to 10/11/2020	-	11,943.36	BENMUNI CSH
E06009L7P9	12/11/2019	Microsoft Regional Sales PTE LTD	Microsoft Office Software License Update 11/11/2019 to 10/11/2020		11,943.36	BENMUNI INV
DD25456.12	14/12/2019	SEEK LIMITED	Environmental Health Officer Advertising on SEEK	-	489.50	BENMUNI CSH
96587283	15/11/2019	SEEK LIMITED	Environmental Health Officer Advertising on SEEK		489.50	BENMUNI INV
DD25474.10	25/12/2019	AUSTRALIAN SUPER	Superannuation contributions	-	4,322.94	BENMUNI CSH
SUPER	25/12/2019	AUSTRALIAN SUPER		2,989.15	BENMUNI	INV
DEDUCTION	25/12/2019	AUSTRALIAN SUPER		500.00	BENMUNI	INV
DEDUCTION	25/12/2019	AUSTRALIAN SUPER		637.24	BENMUNI	INV
SUPER	25/12/2019	AUSTRALIAN SUPER		56.42	BENMUNI	INV
SUPER	25/12/2019	AUSTRALIAN SUPER		69.58	BENMUNI	INV
SUPER	25/12/2019	AUSTRALIAN SUPER		70.55	BENMUNI	INV
DD25474.11	25/12/2019	CONSTRUCTION & BUILDING INDUSTRY SUPER	Superannuation contributions	-	208.86	BENMUNI CSH
SUPER	25/12/2019	CONSTRUCTION & BUILDING INDUSTRY SUPER		208.86	BENMUNI	INV
DD25474.12	25/12/2019	COMMONWEALTH BANK OF AUST	Superannuation contributions	-	104.40	BENMUNI CSH
SUPER	25/12/2019	COMMONWEALTH BANK OF AUST		104.40	BENMUNI	INV
DD25474.13	25/12/2019	MTAA SUPERANNUATION FUND	Superannuation contributions	-	199.88	BENMUNI CSH

SHIRE OF COLLIE**List of Accounts Submitted to Council - December 2019**

Chq/EFT	Date	Name	Description	Amount	Bank	Type
SUPER	25/12/2019	MTAA SUPERANNUATION FUND		199.88	BENMUNI	INV

Bank Code

BENMUNI

903,269.78

BENTRUST

-

903,269.78**Certificate of Chief Executive Officer**

This schedule of accounts to be passed for payment, covering vouchers as above was submitted to each member of Council has been checked and is fully supported by vouchers and invoices which are submitted herewith and which have been fully certified as to the receipt of goods and the rendition of services and as to prices, computations and costings and the amounts shown are due for payment

**SHIRE OF COLLIE
STATEMENT OF COMPREHENSIVE INCOME
FOR THE MONTH ENDED 31 DECEMBER 2019**

BY PROGRAM

		Original Budget	YTD Budget	YTD Actual	Variance (under)/over	Variance (under)/over
		\$	\$	\$	\$	%
Revenue						
Governance	1	71,700	21,048	55,192	34,144	162%
General purpose funding		8,151,583	7,185,580	6,759,165	(426,415)	-6%
Law, order, public safety	2	1,116,595	189,356	829,700	640,344	338%
Health		11,000	5,496	10,895	5,399	98%
Education and welfare		11,168	5,580	0	(5,580)	-100%
Housing		4,500	2,250	2,112	(138)	-6%
Community amenities		1,734,577	1,424,414	1,436,939	12,525	1%
Recreation and culture	3	583,805	108,133	153,674	45,541	42%
Transport		1,672,074	737,435	824,860	87,425	12%
Economic services		60,150	38,814	38,152	(662)	-2%
Other property and services		153,197	61,598	49,223	(12,375)	-20%
		13,570,349	9,779,704	10,159,912	380,208	
Expenses excluding finance costs						
Governance	4	(439,301)	(248,204)	(181,622)	(66,582)	-27%
General purpose funding	5	(143,048)	(71,502)	(185,255)	113,753	159%
Law, order, public safety	6	(934,080)	(490,680)	(637,315)	146,635	30%
Health		(212,678)	(108,606)	(99,862)	(8,744)	-8%
Education and welfare		(99,702)	(55,582)	(50,872)	(4,710)	-8%
Housing		(8,917)	(7,310)	(12,405)	5,095	70%
Community amenities		(2,760,211)	(1,386,703)	(1,253,655)	(133,048)	-10%
Recreation and culture		(3,561,225)	(1,916,963)	(2,063,133)	146,170	8%
Transport		(3,542,882)	(1,798,872)	(1,646,803)	(152,069)	-8%
Economic services		(810,317)	(460,818)	(424,201)	(36,617)	-8%
Other property and services	7	(146,283)	(133,122)	(278,332)	145,210	109%
		(12,658,645)	(6,678,362)	(6,833,454)	155,092	
Total comprehensive income		911,703	3,101,342	3,326,459		

SHIRE OF COLLIE
STATEMENT OF COMPREHENSIVE INCOME
FOR THE MONTH ENDED 31 DECEMBER 2019

BY NATURE OR TYPE

	NOTE	Original Budget	YTD Budget	YTD Actual	Variance (under)/over	Variance (under)/over
		\$	\$	\$	\$	%
Revenue						
Rates		6,179,602	6,179,602	6,174,973	(4,629)	0%
Operating grants	8	2,002,733	930,796	1,153,200	222,404	24%
Contributions & Reimbursements	9	321,246	135,624	236,975	101,351	75%
Fees and charges		2,095,639	1,709,880	1,651,913	(57,967)	-3%
Interest earnings		173,743	86,865	87,112	247	0%
Other revenue		0	0	0	0	0%
		<u>10,772,963</u>	<u>9,042,767</u>	<u>9,304,174</u>	<u>261,407</u>	
Expenses						
Employee costs		(5,546,887)	(2,762,031)	(2,906,036)	144,005	5%
Materials and contracts		(2,949,986)	(1,629,738)	(1,697,816)	68,078	4%
Utility charges	10	(572,109)	(293,702)	(214,071)	(79,631)	-27%
Depreciation on non-current assets		(2,955,813)	(1,479,492)	(1,522,082)	42,590	3%
Interest expenses		(44,082)	(22,040)	(22,441)	401	2%
Insurance expenses		(477,437)	(477,359)	(466,361)	(10,998)	-2%
Other expenditure	11	(112,332)	(14,000)	(4,646)	(9,354)	-67%
		<u>(12,658,645)</u>	<u>(6,678,362)</u>	<u>(6,833,454)</u>	<u>155,092</u>	
		<u>(1,885,683)</u>	<u>2,364,405</u>	<u>2,470,720</u>	<u>416,499</u>	
Non-operating grants, subsidies and contributions		2,767,256	736,937	855,739	118,802	16%
Profit on asset disposals		30,130	0	0	0	0%
Loss on asset disposals		0	0	0	0	0%
Net result		911,703	3,101,342	3,326,459	535,300	
Other comprehensive income						
Changes on revaluation of non-current assets		0	0	0		
Total other comprehensive income		0	0	0		
Total comprehensive income		911,703	3,101,342	3,326,459		

SHIRE OF COLLIE
STATEMENT OF FINANCIAL POSITION
FOR THE MONTH ENDED 31 DECEMBER 2019

	YTD Actual
	2019/20
	\$
Current Assets	
Cash at Bank	1,993,114
Restricted Asstes, Investments	865,728
Receivables/Debtors	3,142,601
Stock on Hand	41,411
Trust Funds	40,265
Self Supporting Loan Debtors	0
Accrued Interest Loan	482
Others	87,586
Total Current Assets	<u>6,171,185</u>
Current Liability	
Borrowings	56,605
Creditors	309,660
Employee Provision	920,590
Accrued Interest	1,354
Trust Funds	40,267
Finance Lease	0
Others	226,105
Total Current Liability	<u>1,554,581</u>
Current Position Surplus/(Deficit)	<u><u>4,616,604</u></u>
Non Current Assets	
Property Plant & Equipment	29,022,325
Infrastruncture	144,051,976
Deferred Debtors	518,494
Total Non Current Assets	<u>173,592,795</u>
Non Current Liabilities	
Long Service Leave Provision	109,444
Borrowings	1,113,901
Total Non Current Liabilities	<u>1,223,345</u>
Net Assets	<u><u>176,986,054</u></u>
Equity	
Reserves - Asset Revaluation	132,190,494
Accumulated Surplus	43,929,832
Equity-Reserves	865,728
Total Equity	<u><u>176,986,054</u></u>

SHIRE OF COLLIE
CAPITAL PROJECTS & PURCHASES
FOR THE MONTH ENDED 31 DECEMBER 2019

		Original Budget	YTD Actual	Variance (under)/over	Variance (under)/over
				\$	%
Governance					
Replace 102CO (CEO)	Trade	25,000	0	(25,000)	-100%
		(59,000)	0	(59,000)	-100%
		<u>(34,000)</u>	<u>0</u>	<u>(84,000)</u>	
Disposal of 101CO	Trade	15,000	0	(15,000)	-100%
Law, Order & Public Safety					
Worsley Bush Fire Brigade Building	Grant	454,000	325,019	(128,981)	-28%
Cardiff Bush Fire Brigade Building	Grant	192,712	333,170	140,458	73%
		<u>(222,712)</u>	<u>(714,100)</u>	<u>491,388</u>	<u>221%</u>
		<u>424,000</u>	<u>(55,912)</u>	<u>502,865</u>	
Community Amenities					
River Restoration	Reserve Transfer	(72,722)	0	(72,722)	-100%
South 32 River Planting	Grant	30,000	0	(30,000)	-100%
		<u>(30,000)</u>	<u>(26,998)</u>	<u>(3,002)</u>	<u>-10%</u>
		<u>0</u>	<u>(26,998)</u>	<u>(33,002)</u>	
Collie River Water Stop Project	Grant	125,000	0	(125,000)	-100%
		<u>(280,000)</u>	<u>(10,350)</u>	<u>(269,650)</u>	<u>-96%</u>
		<u>(155,000)</u>	<u>(10,350)</u>	<u>(394,650)</u>	
Indoor Swimming Pool Feasibility	Grant	(108,560)	16,995	125,555	-116%
Re-Use Shop Grant	Grant	(45,000)	12,841	57,841	-129%
Recreation & Culture					
Collie Swimming Club(Clubrooms)		(28,185)	0	(28,185)	-100%
Caravan Park Facilities(Disabled Toilets)	2017/18 Loan	(32,000)	0	(32,000)	-100%
Caravan Park Improvements		(6,000)	0	(6,000)	-100%
Roche Park: Soccer Improvements		(10,553)	0	(10,553)	-100%
Roche ParkRepair/stabilise cracking walls	2018/19 Loan	(15,000)	0	(15,000)	-100%
Roche Park: Timber overlay & treatment to Court 3 floor	2018/19 Loan + New Loan	105,000	0	(105,000)	-100%
		<u>(150,000)</u>	<u>0</u>	<u>(150,000)</u>	<u>-100%</u>
		<u>(45,000)</u>	<u>0</u>	<u>(255,000)</u>	
Parks: Small tool replacement		(7,500)	0	(7,500)	-100%
Transport					
LIA Entry Design	Trust	(45,000)	0	(45,000)	-100%
Works: Small tool replacement		(7,500)	0	(7,500)	-100%
MSW Upgrade	Grant	496,500	(301,766)	(798,266)	-161%
		<u>(754,368)</u>	<u>0</u>	<u>(754,368)</u>	<u>-100%</u>
		<u>(257,868)</u>	<u>(301,766)</u>	<u>(1,552,634)</u>	
Financial Assistance Grant Special Project (Coombes Street Bridge)		(582,291)	0	(582,291)	-100%
Economic Services					
Aboriginal River Interpretation Signage		(28,000)	0	(28,000)	-100%
Minninup Pool River Area Planning		(142,000)	(41,266)	(100,734)	-71%
Replace Survey Equipment		(35,000)	0	(35,000)	-100%
Disposal of CO31015 (JCB)		52,000	25,629	26,371	-51%
Total Capital Projects & Purchases		(1,151,179)	(380,827)	(2,577,139)	

**SHIRE OF COLLIE
CONSTRUCTION PROGRAM
FOR THE MONTH ENDED 31 DECEMBER 2019**

		Original Budget	YTD Actual	Variance (under)/over	Variance (under)/over
				\$	%
Regional Road Group Program (RRG)					
Patstone Road (SLK 3.98- SLK 3.58)	2/3 Grant	390,000	4,703	385,297	-99%
Patstone Road (SLK 3.98- SLK 3.58)	2/3 Grant	90,000	0	90,000	-100%
Wellington Dam Road (SLK 6.85- SLK 10.77)	2/3 Grant	75,000	0	75,000	-100%
Wellington Dam Road (SLK0.2- SLK 7.13)	2/3 Grant	270,000	0	270,000	-100%
Roads 2 Recovery					
Worsley Back Road (Extend seal:850m)	Part Grant	150,000	214	149,786	-100%
Shannon Road (Extend seal:650m)	Part Grant	120,000	63,615	56,385	-47%
Hodd Street (Seal 150m)	Part Grant	20,000	21,933	(1,933)	10%
Pathway Program					
Bedlington Street (Allanson)	Council	35,000	0	35,000	-100%
WA Bike Network Program (WABN)					
River Walk (Stage 2)	Grant	200,000	3,532	196,468	-98%
River Walk (Stage 3)	Grant	280,000	324,621	(44,621)	16%
Building Better Region Fund (BBRF)					
River Walk (Stage 2)	Grant	350,000	0	350,000	-100%
Special Projects					
Ferguson Road (road safety barriers)	Council	40,000	0	40,000	-100%
Allanson Primary School (Bus Shelter)	Council	12,000	0	12,000	-100%
Cemetery Roads	Council	20,000	0	20,000	-100%
Drainage Improvements	Council	50,000	12,375	37,625	-75%
Gravel Resheeting	Council	100,000	60,548	39,452	-39%
Road Shoulder	Council	50,000	30,647	19,353	-39%
Total Construction Program		2,252,000	522,187	1,729,813	

SHIRE OF COLLIE
SCHEDULE OF INVESTMENT
FOR THE MONTH ENDED 31 DECEMBER 2019

Investment of funds from Municipal Account

Bank	Account Number	Lodgment Date	Amount Deposited	Interest Rate on Deposit	Date of Maturity	Interest to be earned	Total Investment	Month
Bendigo	Municipal Account 150707859	N/A	1,975,979.99		N/A			
Bankwest	Deal # DL00000078 (was 4864204)	21/10/2019	204,566.26	1.35%	20/01/2020	688.52	2,385,112.51	December
Bankwest	Deal # DL00000079 (was 4864205)	21/10/2019	204,566.26	1.35%	20/01/2020	688.52		

Investment of funds from Reserve Account

Bank	Account Number	Lodgment Date	Amount Deposited	Interest Rate on Deposit	Date of Maturity	Interest to be earned	Total Investment	Month
Bendigo	Reserve Account 150707883	N/A	590,011.60		N/A			
Bankwest	Deal # DL00000080 (was 4864207)	21/10/2019	204,566.26	1.35%	20/01/2020	688.52	794,577.86	December

Investment of funds from Trust Account

Bank	Account Number	Lodgment Date	Amount Deposited	Interest Rate on Deposit	Date of Maturity	Interest to be earned	Total Investment	Month
Bendigo	Trust Account 150707891	N/A	40,348.66		N/A		40,348.66	December

**SHIRE OF COLLIE
RATING REPORT
FOR THE MONTH ENDED 31 DECEMBER 2019**

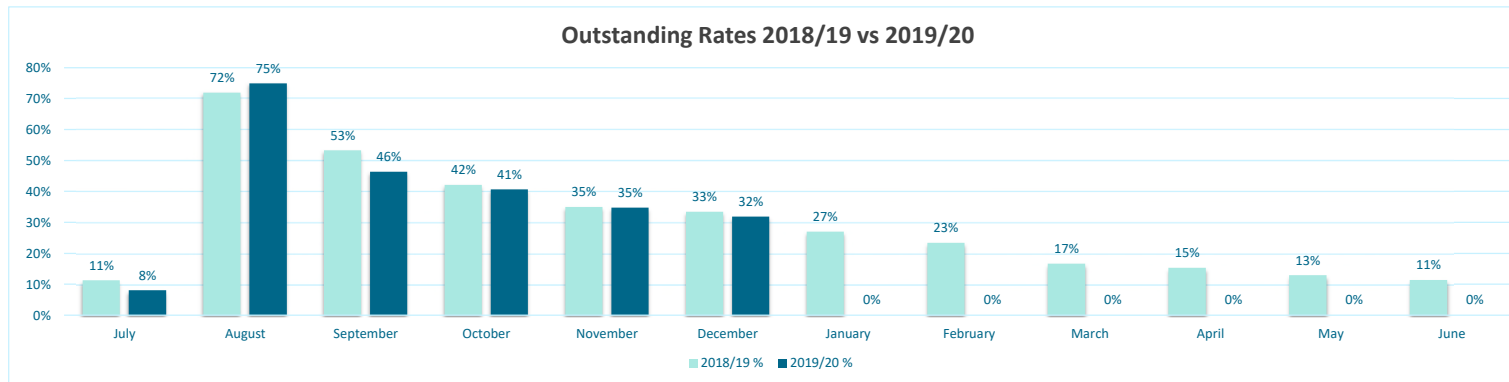

	2013/14		2014/15		2015/16		2016/17		2017/18		2018/19		2019/20	
Key Rating Dates														
Rates Issued	5 August		4 August		3 August		8 August		8 August		7 August			
Rates Dues	9 September		8 September		7 September		12 September		12 September		11 September			
2nd Instalment due	4 November		10 November		9 November		15 November		13 November		13 November			
3rd Instalment due	6 January		12 January		11 January		16 January		15 January		15 January			
4th Instalment due	6 March		13 March		14 March		21 March		19 March		12 March			
Current Year Rates	\$ 5,198,080		\$ 5,335,144		\$ 5,586,634		\$ 5,806,040		\$ 5,924,863		\$ 6,079,315		\$ 6,180,238	
Outstanding Rates from Previous Year	2,275,730		424,602		436,776		687,501		830,192		802,081		802,081	
Deferred Rates from Previous Year	251,826		283,630		314,965		337,797		377,963		398,352		426,629	
	7,725,636		6,043,376		6,338,375		6,831,339		7,133,018		7,279,748		7,408,949	
Outstanding-Monthly Breakdown	\$	%	\$	%	\$	%	\$	%	\$	%	\$	%	\$	%
July	7,443,880	30%	399,561	7%	5,873,903	97%	563,372	8%	633,887	9%	785,536	11%	584,657	8%
August	6,320,937	82%	4,530,655	75%	4,610,913	73%	5,207,922	76%	5,051,806	71%	5,256,664	72%	5,547,554	75%
September	4,892,749	63%	2,831,223	47%	2,918,656	46%	3,703,649	54%	3,477,433	49%	3,892,320	53%	3,436,053	46%
October	4,494,111	58%	2,470,447	41%	2,702,900	43%	2,923,435	43%	3,096,692	43%	3,079,592	42%	3,009,271	41%
November	4,168,642	54%	1,947,129	32%	2,321,379	37%	2,430,114	36%	2,565,164	36%	2,554,883	35%	2,576,418	35%
December	4,016,305	52%	1,785,571	30%	2,173,979	34%	2,290,265	34%	2,393,355	34%	2,438,716	34%	2,361,938	32%
January	3,682,472	48%	1,321,277	22%	1,426,871	23%	1,781,208	26%	1,875,770	26%	1,974,815	27%		0%
February	3,456,456	45%	1,151,934	19%	1,228,991	19%	1,530,595	22%	1,669,979	23%	1,710,357	23%		0%
March	3,167,083	41%	707,831	12%	813,730	13%	1,076,642	16%	1,137,517	16%	1,213,911	17%		0%
April	2,800,338	36%	600,303	10%	734,362	12%	1,004,571	15%	1,019,853	14%	1,121,043	15%		0%
May	2,721,370	35%	538,275	9%	673,807	11%	901,163	13%	936,438	13%	941,543	13%		0%
June	424,602	5%	436,776	7%	585,102	9%	687,501	10%	830,192	12%	802,081	11%		0%

Received 14 JAN 2020

Appl No. P038/19 PAY \$ 6008

Application for Residential Design Codes Approval single house and outbuildings

To: City/Town/Shire/other of: Shire of Collie

Note: This is not an application for planning approval.

Application for single house and outbuilding approval is to be made on this form if an application for planning approval is not required under the local planning scheme and the proposed development involves one of the following:

- the judgement of merit by the decision-maker under the Residential Design Codes
- the judgement of merit by the decision-maker under a local planning policy made in accordance with the scheme.

If you are in doubt about whether application should be made on this form, please consult the decision-maker's planning or building officers.

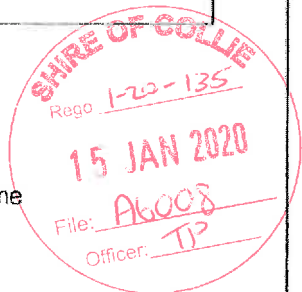

Owner details:

Name:	E & K Martin		
Address:	47 Booth St Collie WA	Postcode:	6225
Signature:	<i>pp. A. Stewart</i>	Date:	09/01/2020
Signature:		Date:	

All owners must sign this form or an attachment if there is not sufficient space. State your position where signing on behalf of a company. This application will not proceed otherwise.

Applicant details:

Name:	Henderson Hardware		
Address:	137 Throssell St Collie WA 6225		
Contact person:	Ash Stewart	Phone:	97341322
		Fax:	97341332
Email:	henhard@bigpond.n	Signature:	<i>A. Stewart</i>
		Date:	9/1/20

Property details:

Lot no:		House/street no:	47		
Street name:	Booth St				
Suburb:	Collie				
Location no:		Diagram/plan no:		Certificate of title no:	
		Folio:			
Nearest street intersection:	Krakouer St				
Title encumbrances (eg easements, restrictive covenants):					
Approximate cost of proposed development:	\$7000				

Please fill in the details on the reverse

Details of proposal subject to judgement of merit

1. Please identify which specific design principle(s), from Part 5 of the Residential Design Codes, the proposal applies (which will require judgement of merit).
2. Please provide full reasons in support of the application of each design principle.
3. Attach further information in support if needed and as required by Part 3 of the Residential Design Codes.

Post height greater than 2.4m

PRINT

Office use only

Accepting officer's initials:

Date received:

Council reference no:

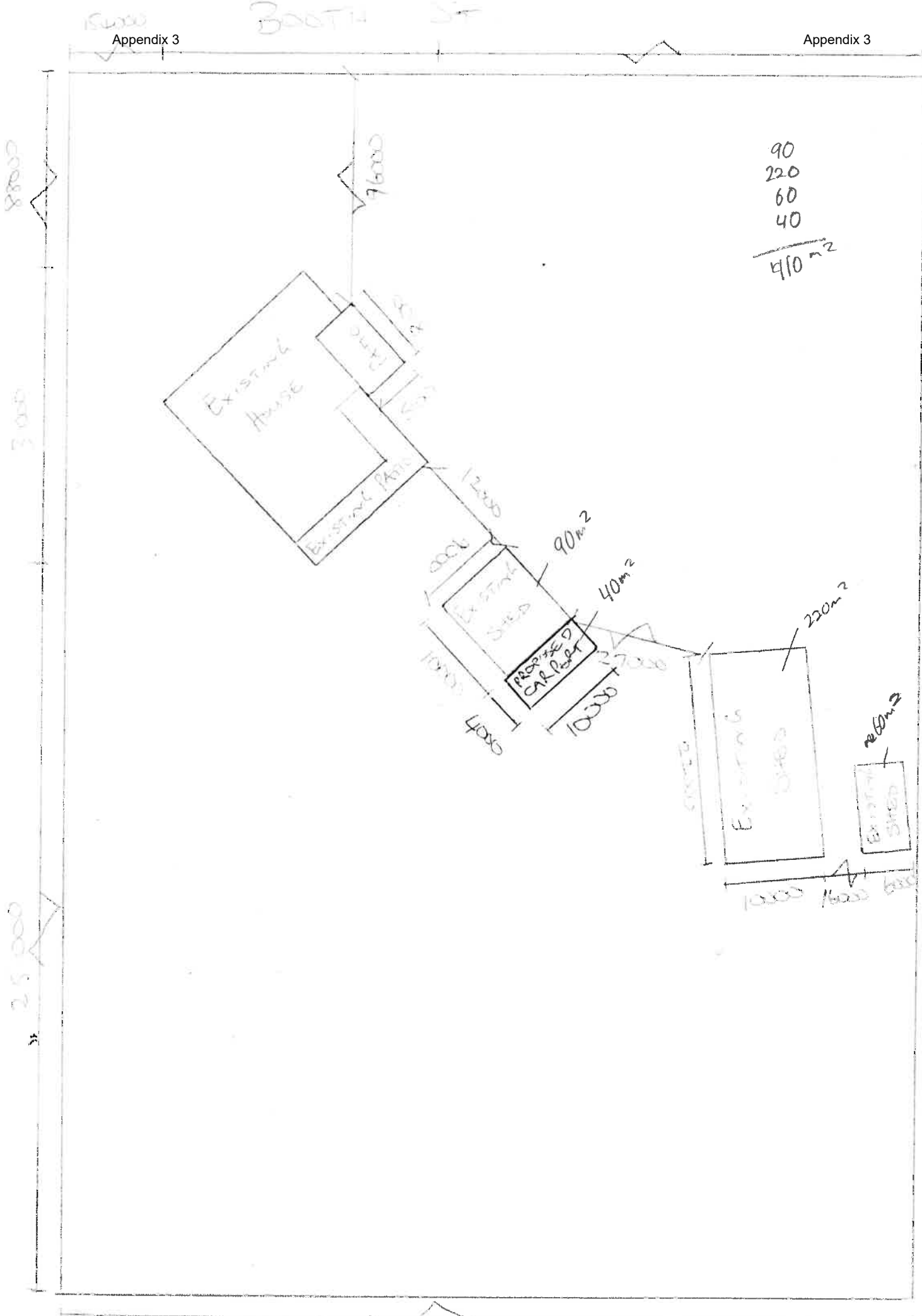

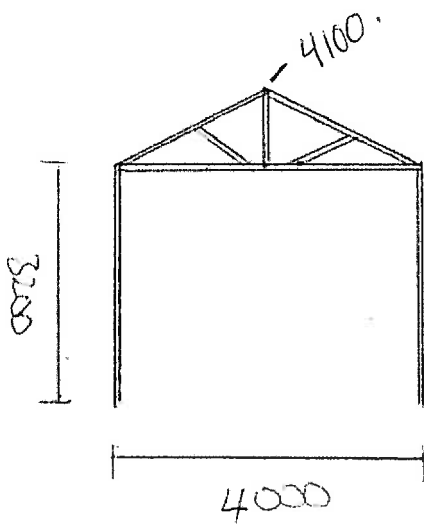
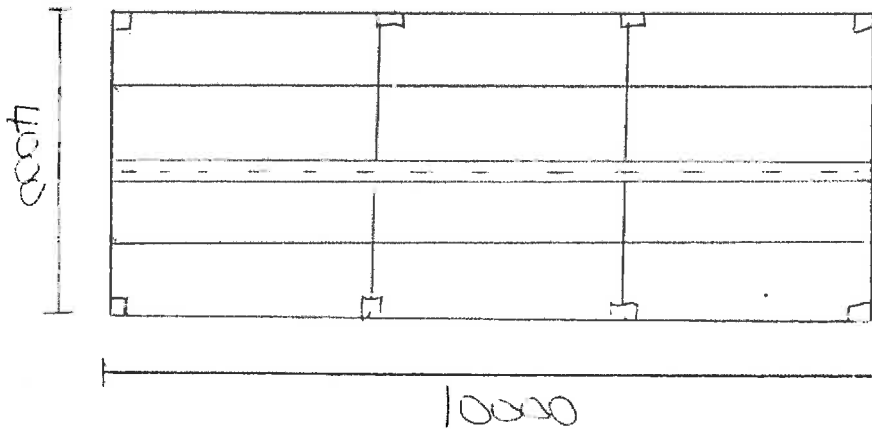

DO NOT SCALE

NOTES:

- DESIGN CRITERIA : AS 4055 WIND REGION A CLASSIFICATION N1 / N2 TOPOGRAPHIC CLASSIFICATION T1 AS 1170 WIND REGION A IMPORTANCE LEVEL 2 Vr = 45ms TERRAIN CATEGORY 3 SHIELDED LOCATION
- SITE WORKS SHALL BE IN ACCORDANCE WITH THE LOCAL COUNCIL'S REQUIREMENTS.
- IF CLAY OR OTHER EXPANSIVE MATERIALS ARE FOUND ON SITE, NOTIFY SUPERINTENDANT IMMEDIATELY BEFORE PROCEEDING WITH WORKS.
- ALL ROOF AND SITE DRAINAGE ARE TO BE DIRECTED AWAY FROM THE BUILDING AREA AS REQUIRED ON SITE.
- ROOF SHEETING AT 10° TO 22.5 PITCH. (MAX. SPAN AS SPECIFIED BY THE MANUFACTURER, FIXED TO MANUFACTURER'S SPECIFICATIONS)
- PROVIDE 76x38x1.6 RHS BRACE EACH SIDE OF ALL COLUMNS FOR FREESTANDING STRUCTURES ONLY.

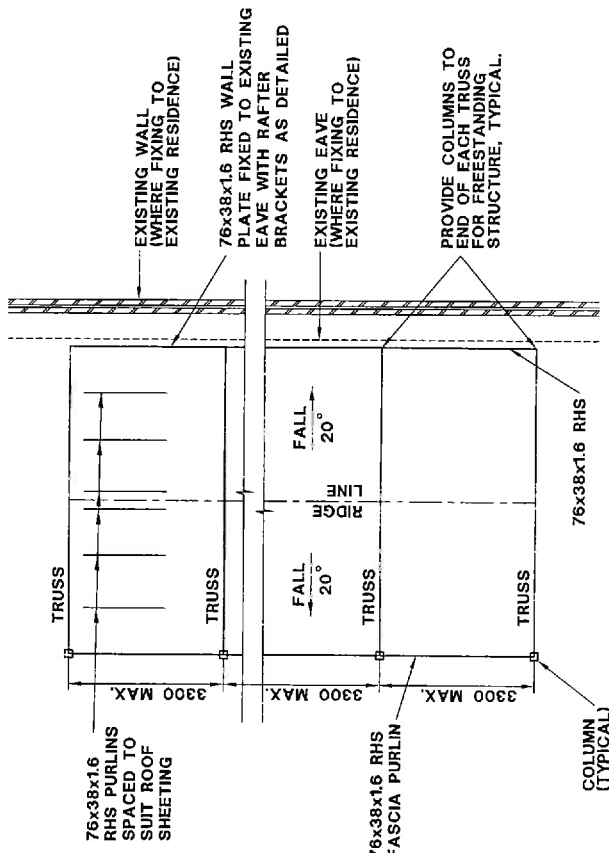

PLAN OF ATTACHED OR FREESTANDING STRUCTURE

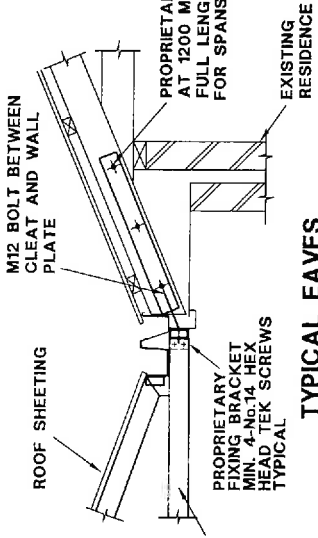

TYPICAL EAVES CONNECTION DETAIL FOR ATTACHED STRUCTURE

- NOTE: CONFIRM EXISTING ROOF TIE DOWNS ARE A MINIMUM OF 32x1.2 STRAP, 1800 LONG AT 1800 MAX. CTS. PLACE DIA. TO TIE DOWN ROD, 1800 LONG AT 1500 MAX. CTS. IF EXISTING TIE DOWN IS NOT ADEQUATE.

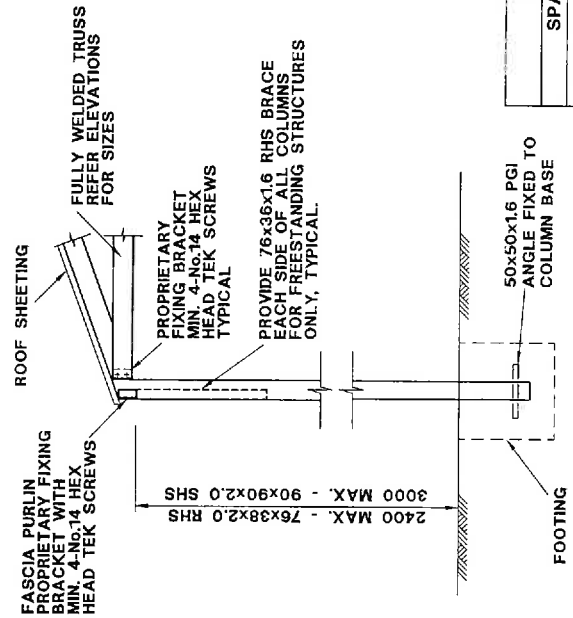

TYPICAL FOOTING DETAIL FOR ATTACHED OR FREESTANDING STRUCTURE

FOOTING SCHEDULE	
SPAN	FOOTING SIZE
4500 MAX.	375x375x375 DEEP
6000 MAX.	450x450x450 DEEP
8000 MAX.	600x600x600 DEEP



TRUSS TO 3500 SPAN

NOTE: ALL MEMBERS 76x38x1.6 RHS MIN. TRUSS SHALL BE FULLY WELDED.

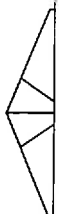

TRUSS TO 4500 SPAN

NOTE: ALL MEMBERS 76x38x1.6 RHS MIN. TRUSS SHALL BE FULLY WELDED.



TRUSS TO 6000 SPAN

NOTE: ALL MEMBERS 76x38x1.6 RHS MIN. TRUSS SHALL BE FULLY WELDED.

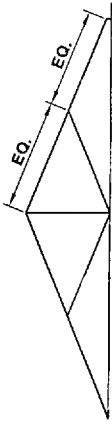

TRUSS TO 8000 SPAN

- NOTE: • BOTTOM CHORD 100x50x2.0 RHS MIN. TOP CHORDS AND WEBS 76x38x1.6 RHS MIN. FOR 7000 MAX. SPAN.
- ALL MEMBERS 100x50x2.0 RHS MIN. FOR 8000 MAX. SPAN.
- ALL TRUSS SHALL BE FULLY WELDED.

AUSSIE OUTDOOR

54 PROFFIT ST,
BUNBURY
PHONE: 9725 4033

GABLE TRUSS PATIO / CARPORT

CLIENT: _____
DATE: _____
VALUE: _____
CONTRACT No.: _____

Civil & Structural ENGINEERS

15 WITTENOOM STREET
BUNBURY, 2230 WA
e-mail: info@cs-engineers.com.au
PHONE: (08) 9791 1824
FAX: (08) 9791 1807

CERTIFICATION No. 2015-6008-011 IS FOR THE STRUCTURAL CERTIFICATION OF A GABLE TRUSS PATIO / CARPORT PRODUCED BY AUSSIE OUTDOOR BUNBURY. CERTIFICATION VOID IF DRAWING ALTERED IN ANY WAY OR ADDITIONAL NOTES ADDED. CERTIFICATION VALID FOR APPLICATIONS BY AUSSIE OUTDOOR ONLY. VALID UNTIL: 31/12/2015.

APPROVED DATE: OCTOBER 2016
P. SUCKLING B.E. (M.E.) (AUST.)



STRUCTURE PLAN

Rural Residential Area No. 12

Booth Street North & Steere Street North

COLLIE



SCALE AT A3 1 : 4000
ALL DISTANCES ARE IN METRES

REV	DRAWN	CHECKED	DRAWING No
JV	22-10-15	LB	22-10-15
B	Modifications as requested by Shire		20226-02E.dgn
C	Inclusion of Drainage Information		08-04-15
D	Modifications as requested by Shire		18-05-15
E	Modifications as approved by Council		02-09-15
			22-10-15

LEGEND

- Structure Plan Boundary
- Existing Boundaries
- Proposed Lot Boundaries
- Gates
- Building Exclusion Area (Fire)
- Building Exclusion Area (Floodplain)
- Floodplain Contours
- Reciprocal Right of Carriageway
- Indicative Drainage Lines / Fazememis
- Drainage Flows
- Contours (5m Interval)

RUMBURY OFFICE:
21 Spencer Street, Rumbury WA 6230
T: 08 9700 9410 F: 08 9721 9451
W: www.harleydykstra.com.au
Office also at Albany, Beaverton, Melville and Perth

COPYRIGHT:
This document is and shall remain the property of HARLEY DYKSTRA.
This document may only be used for the purposes for which it was commissioned and in accordance with the terms and conditions of the commission. Unauthorised use of this document is a breach of copyright law.

NOTE:
This plan has been prepared for planning purposes. Areas, Contours and Distances shown are subject to survey.

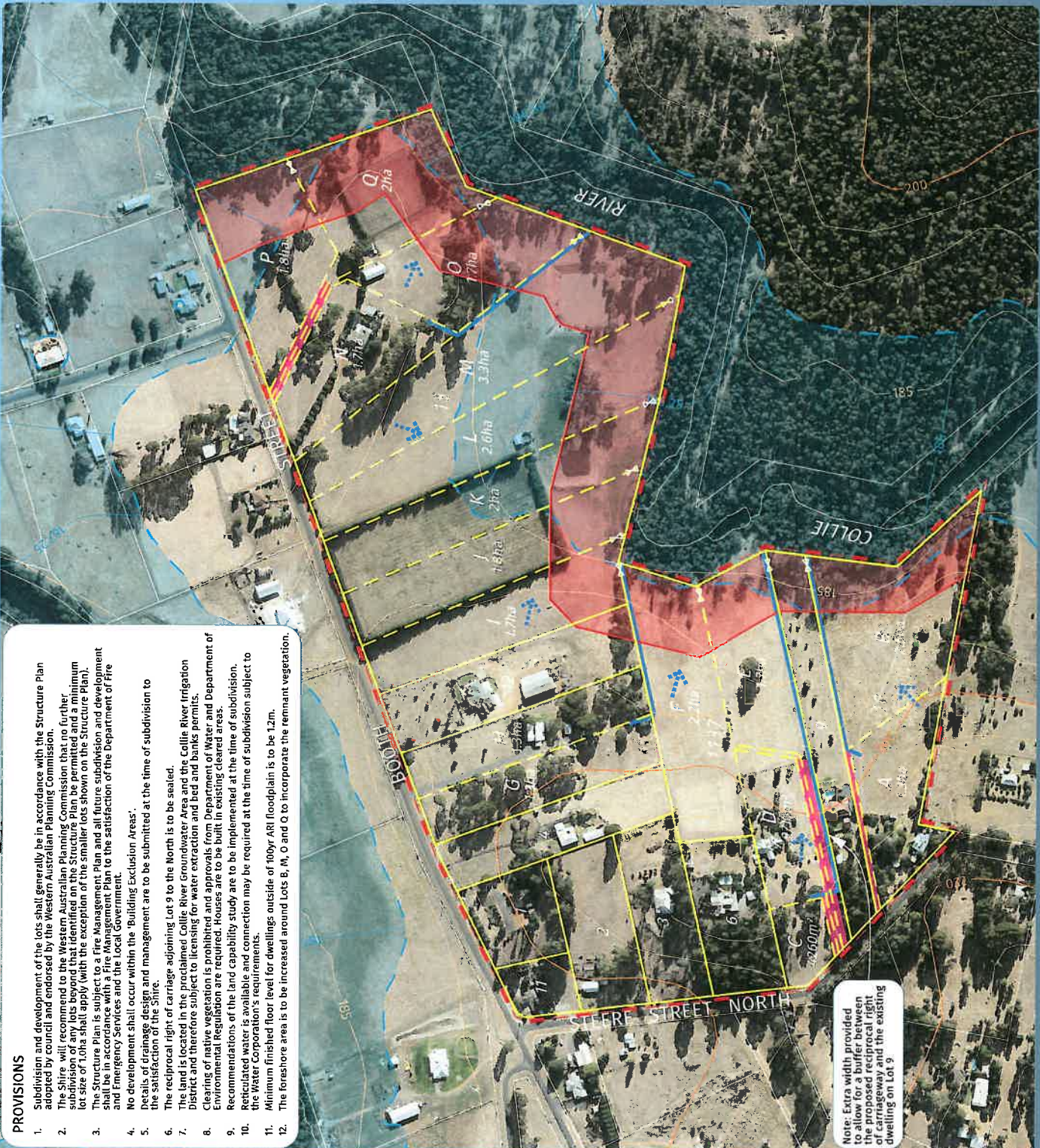

- ### PROVISIONS
- Subdivision and development of the lots shall generally be in accordance with the Structure Plan adopted by council and endorsed by the Western Australian Planning Commission.
 - The Shire will recommend to the Western Australian Planning Commission that no further subdivision of any lots beyond that identified on the Structure Plan be permitted and a minimum lot size of 1.0ha shall apply (with the exception of the smaller lots shown on the Structure Plan).
 - The Structure Plan is subject to a Fire Management Plan and all future subdivision and development shall be in accordance with a Fire Management Plan to the satisfaction of the Department of Fire and Emergency Services and the Local Government.
 - No development shall occur within the 'Building Exclusion Areas'.
 - Details of drainage design and management are to be submitted at the time of subdivision to the satisfaction of the Shire.
 - The reciprocal right of carriage adjoining lot 9 to the North is to be sealed.
 - The land is located in the proclaimed Collie River Groundwater Area and the Collie River Irrigation District and therefore subject to licensing for water extraction and bed and banks permits.
 - Clearing of native vegetation is prohibited and approvals from Department of Water and Department of Environmental Regulation are required. Houses are to be built in existing cleared areas.
 - Recommendations of the land capability study are to be implemented at the time of subdivision.
 - Potential water is available and connection may be required at the time of subdivision subject to the Water Corporation's requirements.
 - Minimum finished floor level for dwellings outside of 100yr ARI floodplain is to be 1.2m.
 - The foreshore area is to be increased around Lots B, M, O and Q to incorporate the remnant vegetation.

Note: Extra width provided to allow for a buffer between the proposed reciprocal right of carriage and the existing dwelling on Lot 9.

FILE COPYRpt No. 265203 Fee \$ 147.00Received **23 DEC 2019**Appl No. 1082/19 PAN A 1439

Application for Residential Design Codes Approval single house and outbuildings

To: City/Town/Shire/other of: Shire of Collie**Note:** This is not an application for planning approval.

Application for single house and outbuilding approval is to be made on this form if

an application for planning approval is not required under the local planning scheme and

the proposed development involves one of the following:

- the judgement of merit by the decision-maker under the Residential Design Codes
- the judgement of merit by the decision-maker under a local planning policy made in accordance with the scheme.

If you are in doubt about whether application should be made on this form, please consult the decision-maker's planning or building officers.

Owner details:

Name:	<u>J Wood</u>		
Address:	<u>35 Ogden St Collie</u>	Postcode:	<u>6225</u>
Signature:		Date:	<u>23.12.19</u>
Signature:		Date:	

All owners must sign this form or an attachment if there is not sufficient space. State your position where signing on behalf of a company. This application will not proceed otherwise.

Applicant details:

Name:	<u>Henderson Hardware</u>		
Address:	<u>137 Throssell St Collie</u>		
Contact person:	<u>Ash Stewart</u>	Phone:	<u>97341322</u>
		Fax:	<u>97341332</u>
Email:	<u>henhard@bigpond.n</u>	Signature:	
		Date:	

Property details:

Lot no:		House/street no:	<u>35 55</u>
Street name:	<u>Ogden St</u>		
Suburb:	<u>Collie</u>		
Location no:		Diagram/plan no:	
		Certificate of title no:	
		Folio:	
Nearest street intersection:	<u>Atkinson St</u>		
Title encumbrances (eg easements, restrictive covenants):			
Approximate cost of proposed development:	<u>\$7000</u>		

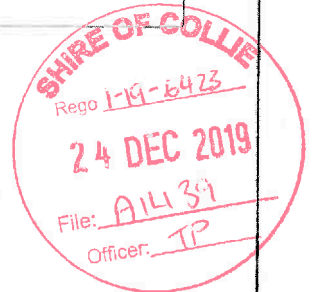
Please fill in the details on the reverse

Details of proposal subject to judgement of merit

1. Please identify which specific design principle(s), from Part 5 of the Residential Design Codes, the proposal applies (which will require judgement of merit).
2. Please provide full reasons in support of the application of each design principle.
3. Attach further information in support if needed and as required by Part 3 of the Residential Design Codes.

Posts to be inside 1m side setback with roofline 500mm from boundary

PRINT

Office use only

Accepting officer's Initials:

Date received:

Council reference no:

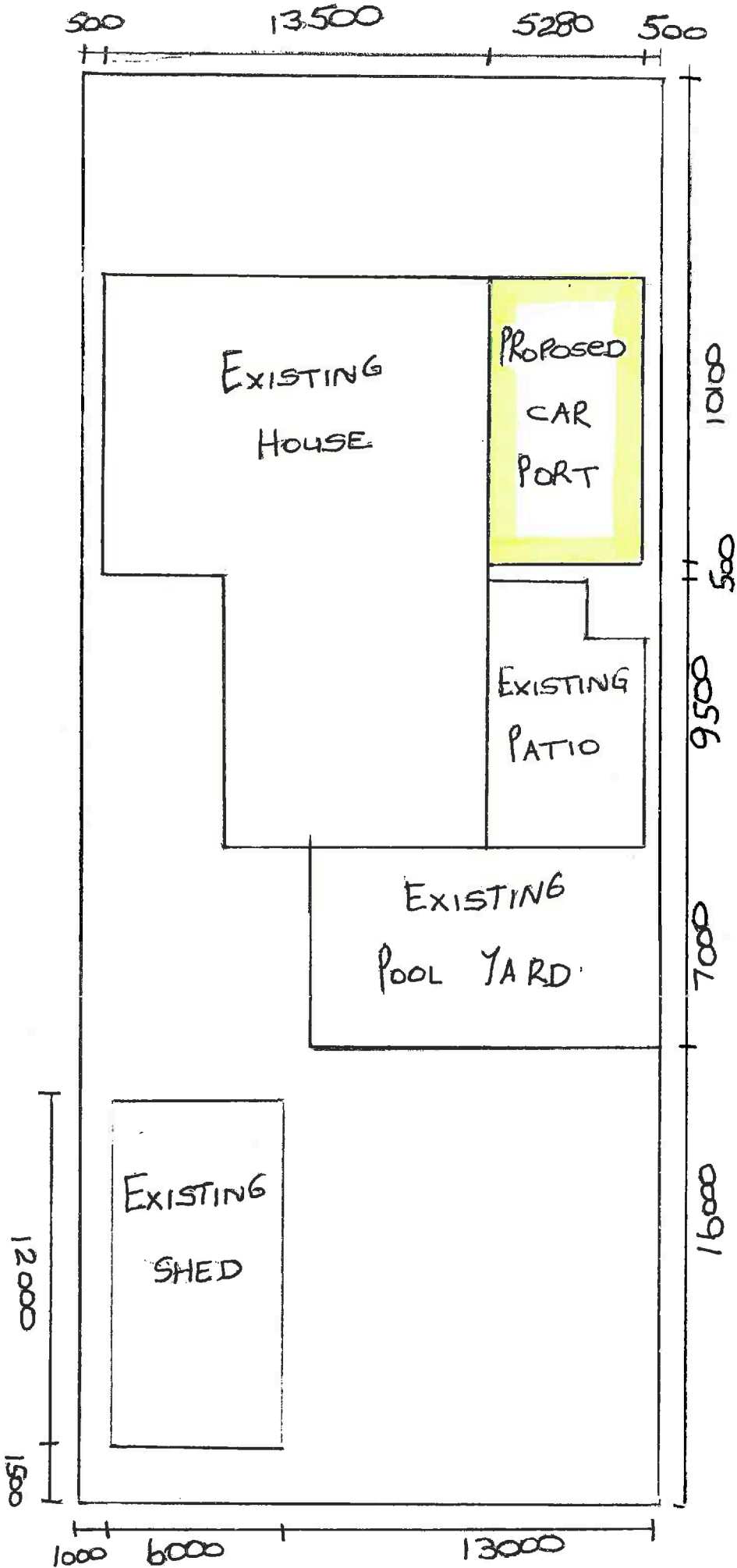

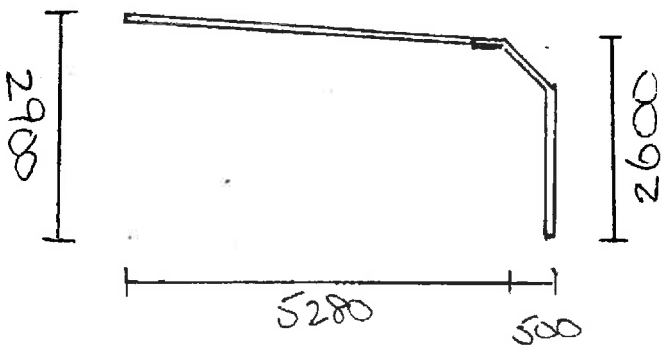
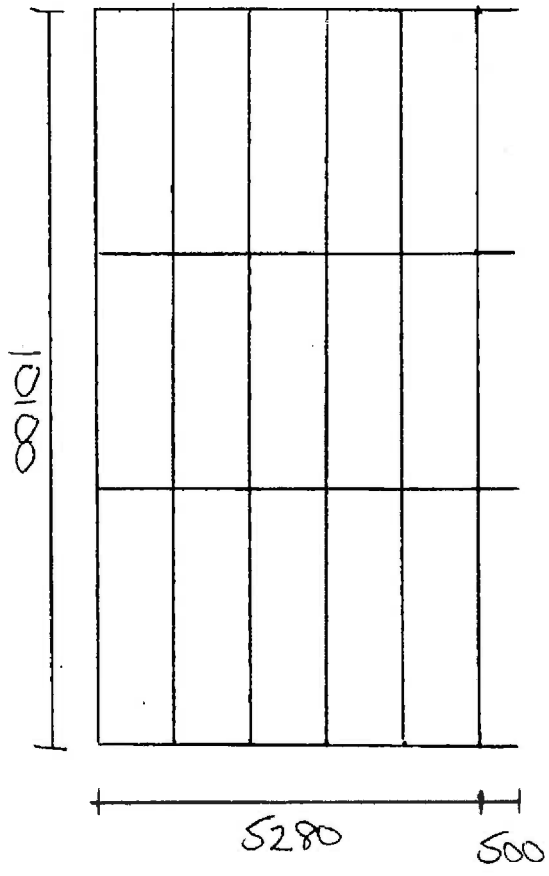

DESIGN CRITERIA
 AS 4055
 WIND REGION A
 CLASSIFICATION N1 / N2
 TOPOGRAPHIC CLASSIFICATION T1
 AS 1170
 WIND REGION A1 / Vr = 45ms
 IMPORTANCE LEVEL 2
 TERRAIN CATEGORY 3
 SHEILDED LOCATION
 CLASS 10 BUILDING
 ROOF - 'TRIMCLAD' SHEETING AT
 3° PITCH. 'OR' '48 HIDECK'
 SHEETING AT 1 PITCH.
 (MAX. SPAN AS SPECIFIED
 BY THE MANUFACTURER.)

MEMBER SCHEDULE (NON TRAFFICABLE ROOF)

BEAMS	MAX SPAN AT 2.7m SPACING	MAX SPAN AT 3.3m SPACING
SIZES		
76mm x 38mm x 1.6mm	3400mm	3200mm
90mm x 38mm x 2.0mm	3900mm	3600
75mm x 50mm x 2.0mm	4600mm	4250mm
100mm x 50mm x 2.0mm	5200mm	4800mm
150mm x 50mm x 2.0mm	6500mm	6000mm

FOOTING SCHEDULE

FOOTING SIZE DEPTH (D)	SIZE (W)
3500mm	450mm
4500mm	500mm
5500mm	550mm
6500mm	600mm

PURLINS

MAX PURLIN SPAN 2700mm	MAX SPAN AT 3.3m SPACING
SIZES	
76x38x1.2 RHS	76x38x1.6 RHS

**54 PROFFIT ST,
 BUNBURY
 PHONE:
 97 254 033**

**AUSSIE
 OUTDOOR**

FLAT PATIO / ENCLOSURE / CARPORT

CLIENT: _____
 DATE: _____
 VALUE: _____
 CONTRACT No: _____

**Civil & Structural
 ENGINEERS**

15 WITTEBOOM STREET
 BUNBURY WA
 e-mail: info@aussieoutdoor.com.au
 PHONE/FAX 9791 1834
 FAX 9791 9157

CERTIFICATION FOR THE STRUCTURAL CERTIFICATION
 OF THE PATIO/ENCLOSURE/CARPORT PRODUCED BY AUSSIE OUTDOOR
 BUNBURY. CERTIFICATION VOID IF DRAWING ALTERED IN ANY WAY OR
 ADDITIONAL VASSES ADDED. CERTIFICATION VALID FOR
 APPLICATIONS BY AUSSIE OUTDOOR ONLY VALID UNTIL 31/12/2018.

DO NOT SCALE

SECTION

PLAN

ENCLOSURE DETAIL

**TYPICAL BRACE DETAIL
 FOR FREE STANDING
 PATIO OR CARPORT**

NOTE
 ALL FIXINGS TO BE MIN 1.2mm PGI

ROOF SHEETING
TRIMCLAD SHEETING
MITRE CUT AND FULLY WELDED

**COLUMN DETAIL
 AT BOUNDARY**

760 MIN
BOUNDARY

DETAIL 1 HALF SADDLE
DETAIL 2 CENTRE COLUMN TOP
DETAIL 3 R.H. CORNER

DETAIL 4 L.H. CORNER
DETAIL 5 EAVES PLATE
DETAIL 6 WALL PLATE

DETAIL 7 COLUMN TOP
DETAIL 8 INTERNAL CLEAT

A. Graham
53 Ogden St
Collie WA
23. 1. 2020

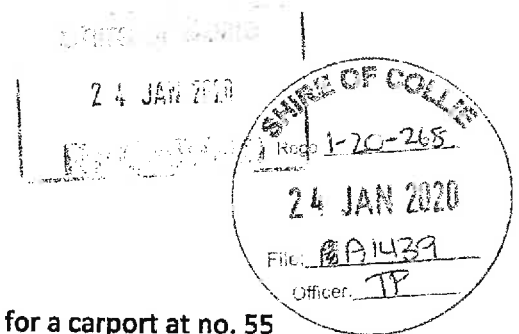

Dear Mr. Quinn,

Thank you for your letter asking for comment on the proposed plan for a carport at no. 55 Ogden St Collie.

1. We object to any enlarging of carport located on the east side of 55 Ogden St Collie.
 - a) Proposed structure will obstruct the light and ventilation we now benefit from upon the cut back and legalizing of our patio with the assistance of shire staff.
 - b) Light and ventilation will be completely blocked from our lounge window / lounge room. 53 Ogden St. was built in 1928 and retains the original floor plan. Enlarging / extension of carport at 55 Ogden St will interfere with the relaxation, privacy use of our patio.
 - c) The proposed heights of 2.4 to 3m will be measured from land that is already raised and may well be further raised thus have a considerable 'lift' when compared to the 'drop' on the other side. This has already happened with the 'existing patio' which has a height of 3.4m on our side.
 - d) The old single course brick fence could again be used by the owner of 55 Ogden St as a retaining wall to raise land and level his carport placing further undue stress on it. The fence is already being used as a retaining wall by 55 Ogden St, supporting a 3.4m high wall/fence/roof.
 - e) Fire Hazards: There is, as in plans supplied, only a 500mm gap (or tin roof sheeting) from shed to boundary on the west side of No.55. The installed pot belly stove in the east patio at 55 Ogden St has its chimney set very low and is only 450mm from our boundary. This Stove has often done damage to our house and contents. It is a genuine risk and unreasonable hazard when lit. A conflagration could quickly spread due to inadequate fire breaks between houses.

2. We query specifications and plans as supplied to us in your letter dated 15.1.2020.
 - a) Specifications expired 31.12.2019
 - b) Plans received are inaccurate.
 - c) Previous plans and tape measure show the length of extension will actually be 12.1m x 5.4m, if constructed to the maximum of 500mm from east boundary line.
 - d) Plans show existing boundaries between properties on both sides as 500mm. This is not so.
 - e) On the east side plans show patio with 500mm setback. Section shown on plan as 'existing patio' 7.8m long has been roofed and fully enclosed to east boundary.
 - f) Existing sheds' are much more extensive and diverse than shown on plan.
 - g) Incomplete, insufficient structural plans for the proposed 10m x 5.8m carport.

Given the existing encroachments, the current owners of No. 55 Ogden St can be trusted to enlarge and extend the proposed plans once under roof to whatever they want and perhaps seek approval after the fact.

An Alternative to this plan would be to simply update the existing carport in the same location with a similar height . No 55 Ogden St Has very little open coverage to soak up rainfall and given the existing paving, concreting and unrestricted breeding of sheds, covering up an open space will only exacerbate the current rear drainage issues.

Thank You for taking the time to read and consider our concerns.

yours sincerely,



Andrew Graham

Linda Graham

Existing layout

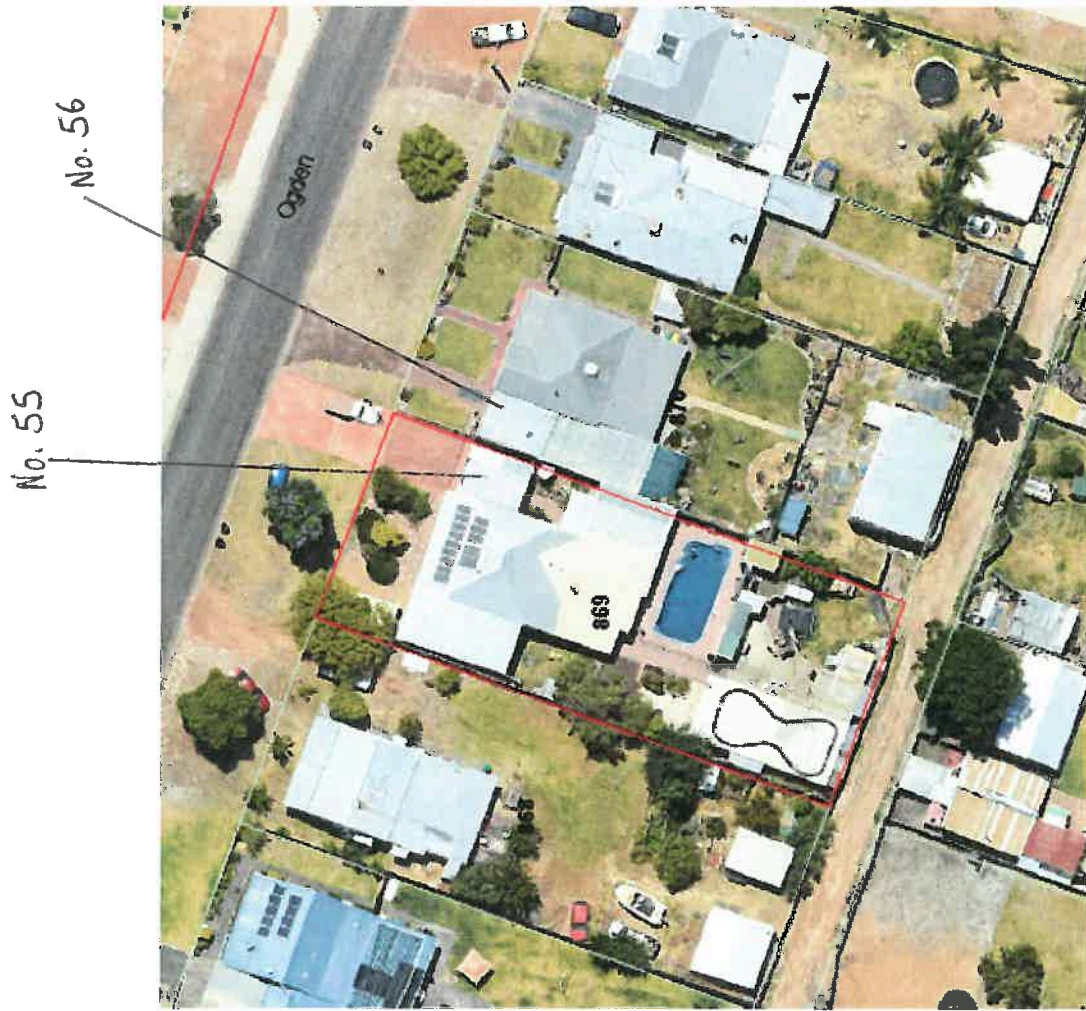







2020 WA Local Government Convention

#SHOWCASE IN PIXELS 2020

Information Pack

FOR FURTHER INFORMATION

Please contact
Public Relations Assistant,
Brenda Law-Yat

T (08) 9213 2085
E blawyat@walga.asn.au

2020

#showcAse IN PIXELS



2019 overall winner Shire of Meekatharra featured on the screens of the Yagan Square Digital Tower.

The annual exhibition of artwork from Local Governments will be displayed at the iconic digital tower at the heart of Yagan Square.

Traditionally (until 2018) the artwork, in the form of physical banners, were hung on the poles along St Georges and Adelaide Terrace. Since 2019, WALGA has the opportunity to display digital artwork designs on the 45-metre high tower at Yagan Square, which features a circular screen with 14 columns, which represents the 14 Noongar language groups.

This new format of display means our participants are no longer restricted to PVC canvas - you are encouraged to be as creative as you can. Please refer to Page 2 for more information.

Competition Categories

The categories are:

- Junior primary school(s) (Pre-primary - Year 3)
- Upper primary school(s) (Year 4 - 6)
- Secondary school(s) (Year 7 - 12)
- Community group(s) / Non-Professional
- Professional / Digital (including digitally designed prints, artist-produced banners)

Indicate Your Interest

There is no reservation form to be completed this year as the digital display means we can accept one submission from every Council in WA. However, please email Public Relations Assistant, Brenda Law-Yat at blawyat@walga.asn.au by Friday, 20 March to indicate your interest in participating. Please include the following information in your email message:

- Council
- Council Contact Person for the Competition
- Category: Junior Primary/Upper Primary/ Secondary/ Community/ Professional or Digital/ Unconfirmed
- School/Artist (if known)

Each Council is only allowed one artwork submission. Your submission will not be accepted if you do not express interest by Friday, 20 March.

Note: WALGA will only accept entries from Local Governments – please approach your local Shire/Council if you are not a Local Government staff member.

Artwork Painting and Digital Images

As there is no limit on the choice of media or canvas, feel free to be creative! There is no need to use weather-proof paint nor a specific PVC canvas.

The canvas can be in any material - some canvas ideas are:

- Floor
- Pavement
- Wall
- Fabric/Canvas
- Paper

You can also use any media, such as:

- paint
- materials to create a collage, even recyclable items
- mosaic art
- mixed media

However, please be aware that the following specs for the canvas needs to be followed:

Size of canvas: in ratio of height is to width:

1.38 (height) : 1 (width)

For **digitally-created** banners, please create your submission in this dimension:

896 pixels (height) by 650 pixels
(width)

Digitally-created artwork can only be included in the Professional/Digital category.

Please submit a word document along with your artwork (maximum of 250 words) to provide an explanation of your submission:

- how it is created
- which medium is used
- inspiration behind each element or the composition, and
- the competition category.

If you have any question or would like to discuss artwork ideas, please give PR Assistant Brenda Law-Yat a call on 9213 2085.

Guidelines for Submission

As the digital tower faces the road, the following guidelines must be strictly adhered to:

- **No solid red, green or orange/amber colours**
- **No photograph/pictures of road networks or traffic**
- **Content cannot include colours or shapes that could be mistaken for traffic signals, signs or instruction signs**
- **Composition should not be chiefly made up of dark images as they will not be visible during the day.**

2019 WINNERS

Judging Criteria

Use bold lettering to stand out from the crowd – each submission has to include the name of the relevant Council.

The Convention Theme for this year is:



Keep any written messages short and simple, and use large and clear lettering. According to the category the banner has been entered in, the judges will consider:

- Is it easy to identify where the banner comes from?
- Can you easily read the Council's name?
- How is the composition of the piece?
- Can you identify something about the place? e.g. does it depict wildflowers, farming, coffee strip etc
- Use of colour and creativity
- Artistic merit
- Individuality, boldness, and humour.

Deadline

The artwork must be submitted via email (blawyat@walga.asn.au) by COB Friday, 29 May.

All entries are subjected to the approval of WALGA before they can be included in the digital slideshow.

Failure to send through your submission by the deadline will mean that the Association is unable to include the submission in the digital display slideshow.



OVERALL WINNER and Best Secondary School:
Shire of Meekatharra



Best Junior Primary School:
Shire of Ashburton



Best Upper Primary School:
Shire of Broomehill-Tambellup

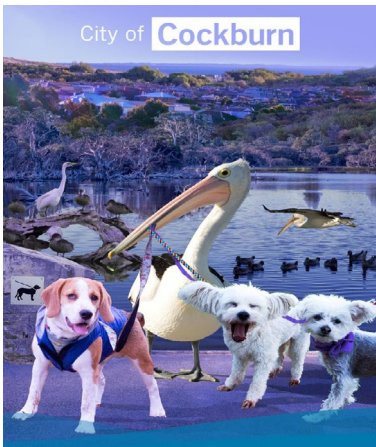

Best Digital /Professional:
City of Cockburn



Best Community Group/ Non-Professional
Shire of Corrigin

Click here to view the media release on 2019 #shoWcAse in Pixels winners and view comments from the judges.



Submitting the Artwork

Please do not send the physical artwork to the Association. Submit photographs of the artwork or the digital piece to PR Assistant Brenda Law-Yat blawyat@walga.asn.au by COB Friday, 29 May.

If your artwork is not created digitally, you will need to take a photograph of the banner. We recommend the photograph be taken from a height so as not to skew the banner. Please ensure the entirety of the artwork is captured in the photograph.

The photograph or digital submission needs to be 300 DPI. When sending through the photograph, select the original size (do not resize the image or choose a smaller file size).

If the file size is too large, consider creating a dropbox account (www.dropbox.com), uploading onto dropbox before sending through the link.

For digitally-created banners, please create your submission in this dimension: 896 pixels (height) by 650 pixels (width) in 300 DPI.

Please submit a word document along with your artwork (maximum of 250 words) to provide an explanation of your submission (eg how it is created, which medium is used, inspiration behind each element or the composition) and the competition category.

IMPORTANT DATES

Before Friday, 20 March:

Send an email to PR Assistant Brenda Law-Yat blawyat@walga.asn.au indicating your interest in participating with the following information:

- Council
- Council Contact Person for the Competition
- Category: Junior Primary/Upper Primary/Secondary/ Community/ Professional or Digital/ Unconfirmed
- School/Artist (if known)

Note: WALGA will only accept entries from Local Governments – please approach your local Shire/ Council if you are not from Local Government.

Your submission will not be accepted if you do not express interest by Friday, 20 March.

Between now to Thursday, 28 May:

Create the artwork - Council contact person should stay in touch with the artist/ school/ community groups. Please inform your artist of the following guidelines that **MUST BE FOLLOWED**:

- **No solid red, green or orange/amber colours**
- **No photograph/pictures of road networks or traffic**
- **Content cannot include colours or shapes that could be mistaken for traffic signals, signs or instruction signs**
- **Composition should not be chiefly made up of dark images as they will not be visible during the day.**

Page 2 has more information about the artwork specs.

Thursday, 28 May:

Take a photograph of your artwork, a day before it is due.

Before Friday, 29 May:

Submit the artwork and a word document (max 250 words) explaining the submission via email to PR Assistant Brenda Law-Yat blawyat@walga.asn.au. Refer to above section 'Submitting the Artwork' for more information.



#shoWcAse IN PIXELS 2020



**LEADING
THE WAY**

2020 WA Local Government Convention

FOR FURTHER INFORMATION

Please contact Public Relations Assistant, Brenda Law-Yat

ONE70 LV1, 170 Railway Parade, West Leederville WA 6007
T (08) 9213 2085 | **F** (08) 9213 2077 | **E** blawyat@walga.asn.au
www.walga.asn.au

Motions Report - Closed Since Last Council Meeting

Thursday, 13 February 2020

8312	Closed	CEO	Opportunity to partner in co-operative research program to research transformation of mining economies and mine closure outcomes
<i>Item No</i>	11.2		That Council partner with the University of Western Australia and other organisations in the Co-operative Research Program to transform mining economies and improve mine closure outcomes on an in-kind basis.
<i>Date Moved</i>	12-Nov-19		
<i>Date Completed</i>	13-feb-20		
<i>Comment</i>			
8343	Closed	DCS	Notice of Motion (1) by Cr Faries - Community Safety and Wellbeing Committee
<i>Item No</i>	15		That Council by Absolute Majority:-
<i>Date Moved</i>	10-Dec-19		1. In accordance with provisions of Section 5.8 of the Local Government Act 1995 establishes a Community Safety & Wellbeing Committee;
<i>Date Completed</i>	13-feb-20		2. In accordance with provisions of Section 5.9 of the Local Government Act 1995, resolves that the Committee is to comprise of Councillors, employees and other persons; and
<i>Comment</i>	First formal meeting of the CSAW to be held 19 February 2020.		3. In accordance with provisions of Section 5.10(1)(a) of the Local Government Act 1995 resolves that the Committee shall have as its Members: Councillors Faries, Scoffern, Italiano, Smith The Director Corporate Services The Community Development Officer Representatives from education, the police, health and family support services that are active in Collie, and other relevant stakeholders.
8351	Closed	DCS	Renewal of Lease to Lions Club of Collie Inc
<i>Item No</i>	12.1		That Council;
<i>Date Moved</i>	28-Jan-20		1. lease the property on Reserve 10077 (old Ewington School Site) to the Lions Club of Collie Inc. with the following conditions:
<i>Date Completed</i>	13-feb-20		d. lease to be deemed a Long-Term lease with a term of 5 years with a 5 year option;
<i>Comment</i>	Club advised of Council decision; draft lease to be sent to DPLH for consent.		e. annual lease amount payable be \$1 per annum incl GST; and f. Other conditions to be in accordance with Council policy DS1.3.
			2. consider an amount of \$5,500 for the external painting of the building to the 2020/21 budget considerations.

Motions Report - Closed Since Last Council Meeting

Thursday, 13 February 2020

8354	Closed	SP	Third Party Appeal Rights in Planning
<i>Item No</i>	13.1		That Council advise WALGA that it, supports the following motion moved at the August 2019 WALGA Annual General Meeting:
<i>Date Moved</i>	28-Jan-20		1. That there be an amendment to the Third Party Appeals Process Preferred Model, being that third parties in addition to Local Governments are able to make an appeal.
<i>Date Completed</i>	13-feb-20		2. That there be an amendment to the Third Party Appeals Process Preferred Model, being that closely associated third parties in addition to Local Governments are able to appeal decisions made by the Western Australian Planning Commission and the State Administrative Tribunal, in addition to Development Assessment Panels.
<i>Comment</i>			
8355	Closed	SP	63 Rowe Street - Proposed Home Business (TraaVerse Tourism Services and Equipment Hire)
<i>Item No</i>	13.2		That Council pursuant to the provisions of the Planning and Development Act 2005, hereby resolves to grant Development Approval to D & S Fraser for a Home Business (Tourism Services) at 63 Rowe Street Collie subject to the following conditions:
<i>Date Moved</i>	28-Jan-20		1. At all times, the development the subject of this planning approval must comply with the definition of 'Home Business', incidental to the main dwelling, as contained in Schedule 1 of the Shire's Local Planning Scheme.
<i>Date Completed</i>	13-feb-20		2. All development shall be in accordance with the approved development plans (attached) which form part of this planning approval.
			3. This approval is valid for a period of 1 (one) year from the date of issue and is subject to annual renewal due on 31st January every year thereafter. The approval is liable to cancellation without compensation at any time for infringement of any breach of any conditions under which it is issued.
			4. The business shall not cause injury to or adversely affect the amenity of the neighbourhood.
			5. Hours of operation shall be limited to: Monday - Friday: 8.00am – 7:00pm Saturday: 8:00am – 7:00pm Sunday/ Public Holiday: 9:00am – 7:00pm
			6. All works required to satisfy a condition of this approval are required to be installed/ constructed and maintained in accordance with the approved plans and conditions of approval for the life of the development.
			7. The use/development is not to interfere with the amenity of the locality or cause nuisance by reason of the emission of noise, vibration, smell, fumes, smoke, vapour, steam, soot, ash, dust, waste water, water products or grit, oil or otherwise.
			8. The business shall not occupy an area greater than 50 square metres.
			9. The business shall not involve retail sale, display or hire of goods of any nature.
			10. The business shall not display a sign exceeding 0.2 square metres. The advertisement/ sign is of a type that is incorporated as part of a building wall, fence or entry statement and not illuminated.
			11. In relation to vehicles and parking, the business shall not result in the requirement for a greater number of parking facilities than normally required for a single dwelling or an increase in traffic volume in the neighbourhood, shall not involve the presence, use or calling of a vehicle more than 2 tonnes tare weight, and shall not include provision for the fueling, repair or maintenance of motor vehicles.
			12. The Shire of Collie advises that failure to comply with all conditions of the planning approval at any time may result in the withdrawal of the home occupation approval.
<i>Comment</i>			

Motion Report - Show All Open Motions

(Sorted by Officer, Motion No.)

Thursday, 13 February 2020

6245	Open	DDS	Adoption of the Recommendations of the Collie Weeds and Waterways Advisory Committee
<i>Item No</i>	11.2		That Council adopts en bloc the recommendations contained within the minutes of the Collie Weeds and Waterways Advisory Committee meeting held on 5 September 2013 as shown below:
<i>Date Moved</i>	22-Oct-13		11.2.1 That Council endorse the design, construction and installation of a series of interpretive signs along the Collie River foreshore between the Co-op and East End Bridges, focusing on local fauna, flora and Noongar cultural beliefs, utilising funds from the SuperTowns River Revitalisation Project.
<i>Date Completed</i>			11.2.2 That Council endorses the Committee's decision to investigate methods of effective removal of Typha Orientalis from the Collie River, with particular attention given to the Venn Street boards area.
<i>Comment</i>	Quotes obtained for signage. Grant applications to Lotterywest has been successful. Procurement ongoing. 11.2.2 Contractor engaged to undertake Typha control; treatment completed 10/05/2014.		
6990	Open	DDS	Adoption of the Recommendations of the Weeds and Waterways Advisory Committee
<i>Item No</i>	11.2		That Council adopts en bloc the recommendations contained within the minutes of the Weeds and Waterways Advisory Committee meeting held on 11 February 2016:
<i>Date Moved</i>	08-Mar-16		11.2.1 That Council endorses the Committee's Recommendation to:
<i>Date Completed</i>			1. Request that the Public Transport Authority agrees to revoke management orders for Reserve 9012 and portion of Reserve 10519
			2. Once the Public Transport Authority agrees to revoke its management order in Reserve 9012 and excise portion of Reserve 10519, requests that the Department of Lands:
			1. Vest or designate Reserve 9012 as 'Water' given that it forms part of the Collie River waterway, or modify the Management Order of Reserve 9012 to vest the land with the Shire of Collie
			2. Excise portion of Reserve 10519 as identified on the attached plan and amalgamate this with Reserve 47298, or create a separate Reserve for Drainage vested in the Shire of Collie
<i>Comment</i>	11.2.2 That Council endorse the Committee's Recommendation to collect Long Term Plans and Allocation Plan information for the river from various organisations and present to the Committee		
	Tender completed. Meeting held on site 15 June 2016 with PTA and Brookfield. Agreed in writing that site will be excised 04 October 2017. Currently complying with exision conditions including a condition to prepare legal indemnity agreement with Arc Infrastructure. This agreement is currently being negotiated.		

Motion Report - Show All Open Motions

(Sorted by Officer, Motion No.)

Thursday, 13 February 2020

7429	Open	CEO	Waste Water Resue Project
<i>Item No</i>	13.1	That Council:	
<i>Date Moved</i>	30-May-17	1.provide in principal support to further investigating using treated waste water from the Mungalup Road waste water treatment facility for irrigation of the Collie Golf Course and other Council reserves if possible; and	
<i>Date Completed</i>		2.authorise staff to seek grant funding opportunities to undertake an initial feasibility assessment of the project.	
<i>Comment</i>	Project put forward to South West Development Commission as a priority in light of Collie Water Proposal. (Feb 2019)		

7522	Open	DDS	Future Use of Former Allanson Bush Fire Brigade Building
<i>Item No</i>	15.1	That Council:	
<i>Date Moved</i>	22-Aug-17	1. Further investigates the development of shed for use by the Allanson Progress Association;	
<i>Date Completed</i>		2. Provide storage at the Former Shire Depot for the Museum Committee for a period of two years and;	
<i>Comment</i>	Action 1 currently being completed by the Allanson Progress Association. Actions 2 & 3 Completed		

7673	Open	DDS	Expression of Inters for Buckingham Hall
<i>Item No</i>	15.1	That Council:	
<i>Date Moved</i>	12-Dec-17	1.Receive the submission from the Buckingham Heritage Group Inc regarding the future of Buckingham hall and grounds;	
<i>Date Completed</i>		2.Seek funding to restore the toilets and hall at Buckingham Hall and grounds;	
<i>Comment</i>	Funding being sought to restore the toilets and hall.		

Motion Report - Show All Open Motions

(Sorted by Officer, Motion No.)

Thursday, 13 February 2020

7809	Open	DDS	Bush Fire Advisory Committee
<i>Item No</i>	10.5		That Council adopts en bloc the recommendations contained within the minutes of the Bush Fires Advisory Committee held on 17 May 2018.
<i>Date Moved</i>	28-May-18		That Council:
<i>Date Completed</i>			<p>10.5.11. Accept the tender from Bio Growth Partners PTY LTD previously called for mechanical fuel reduction on reserve 36801 on a cost neutral basis; and</p> <p>2. That Shire officers further investigate Shire reserves that require fuel reduction and risk mitigation for the mechanical fuel reduction process and provide a report to Council on reserves upon finalisation of the investigations.</p> <p>10.5.4That Council write to the Ministers for Fire and Emergency Services and Volunteers and the Association of Volunteer Bush Fire Brigades President, highlighting the issue of volunteer fire fighters not being eligible for Income Protection Insurance by insurance companies across Australia and outline the risk to their families and income if they were to be injured or become sick from any source other than fire fighting duties.</p> <p>10.5.5That Council Purchase Dress Shirts for Brigade Officers to raise the professionalism of brigades and enhance the public image of the volunteers. The Dress shirt would be the D1374-YB-VBFB Shirt available from Stewart and Heaton as the standard Bush Fire Brigade Shirt for Dress requirements, modified to show Shire of Collie logos and positions.</p>
<i>Comment</i>	10.5.2 ongoing 10.5.1, 10.5.4 and 10.5.5 completed		
7830	Open	DTS	Townscape Advisory Committee
<i>Item No</i>	10.2		That Council adopts en bloc the recommendations contained within the minutes of the Townscape Advisory Committee held on 5 June 2018.
<i>Date Moved</i>	19-Jun-18		10.2.1That the Townscape Advisory Committee respond to the Miners Welfare Board confirming that the wording for the Patterson Road sign will include the entire history from the commencement of Coalfields to present time.
<i>Date Completed</i>			10.2.2That staff research a suitable lighting and sound company for a draft proposal to projecting lighting onto buildings surrounding the overhead bridge.
			10.2.3That Council allocate an amount of \$16,000 in the draft 2018/19 budget for street tree planting along Prinsep and Wittenoom Streets.
<i>Comment</i>	Awaiting revised wording from Townscape Committee (Nola and Leonie)		

Motion Report - Show All Open Motions

(Sorted by Officer, Motion No.)

Thursday, 13 February 2020

8076	Open	DDS	Collie Futures Industry Development Fund Grant Application - Trails
<i>Item No</i>	13.3		That Council:
<i>Date Moved</i>	05-Mar-19		1. Apply to the Collie Futures Fund Grant for the development of trails in the region; and
<i>Date Completed</i>			2. Allocate contributing funding for this grant of \$100,000 in each of the 19/20 and 20/21 financial years should this grant application be successful.
<i>Comment</i>	Advised by the South West Development Commission to delay pending the State funding announcement. Further discussions are taking place with DBCA to coordinate this. Relate Item to EDAC 15/08/2019. Item deferred until next EDAP.		

8082	Open	DDS	Legal Matter
<i>Item No</i>	20.4		That Council:
<i>Date Moved</i>	05-Mar-19		1. Provide a final opportunity for Smargiassi Nominees to cease the unlawful use of the land and remove all material from Lot 1 Scenic Drive within 2 weeks of notification; and
<i>Date Completed</i>			2. Commence legal proceedings against Smargiassi Nominees for the use of in contravention of the Planning and Development Act 2005 should non-compliance continue following the receipt of the above correspondence.
<i>Comment</i>	Letter issued 7 March 2019 and inspection taken place. A writ is being considered by the Supreme Court for this property.		

Motion Report - Show All Open Motions

(Sorted by Officer, Motion No.)

Thursday, 13 February 2020

8094	Open	CESO	Adopt the Recommendation of the Minutes of the Bush Fires Advisory Committee
<i>Item No</i>	10.2		10.2.2defer the decision on the below motion until advice is sought from the Association of Volunteer Bush Fire Brigades of Western Australia and presented to Bush Fire Advisory Committee for assessment.
<i>Date Moved</i>	26-Mar-19		
<i>Date Completed</i>			That Council refer the Shire of Collie Bushfire Brigades Guidelines to the Policy Review Committee to include provisions that: 1. Commences the use of a Medical Declaration Form, Medical Clearance Form and the requirement to obtain a National Police Certificate for new applicants to join the Shire of Collie Bush Fire Brigades; 2. Provides discretion to the Chief Executive Officer to refuse membership applications if a conviction of a serious nature is shown on the National Police Clearance; and 3. Allows persons who cannot obtain a medical clearance to become an auxiliary member of the Shire of Collie Bush Fire Brigades.
			10.2.3That Council approve the Memorandum of Understanding (Attached Appendix) and become signatory to the document to establish mutual emergency response capability arrangements for bushfires within or near plantation estates and for bushfires where plantation resources may be used to support the local bushfire fighting response.
			10.2.4That Council; 1. Receive the draft Shire of Collie Bush Fire Brigades Social Media Policy; and 2. Refer the draft Shire of Collie Bush Fire Brigades Social Media Policy to the Policy Review Committee.
<i>Comment</i>	Association unwilling to provide formal reply, Will present motion at next BFAC without comment from Association		
8097	Open	DDS	Adopt the Recommendation of the Minutes of the Weeds and Waterways Advisory Committee
<i>Item No</i>	10.4		That Council adopts en bloc the recommendations contained within the minutes of the Weeds and Waterways Advisory Committee held on 7 March 2019.
<i>Date Moved</i>	26-Mar-19		That Council reinvestigate ways in which water levels in the South Branch of the Collie River can be kept at acceptable levels during the dry season on behalf of downstream ratepayers.
<i>Date Completed</i>			
<i>Comment</i>	Monitoring water levels to determine the extent of the issue (if any) during the dry season. Letter sent to the Premier, Local Member and DWER in relation to this in accordance with motion 8219.		

Motion Report - Show All Open Motions

(Sorted by Officer, Motion No.)

Thursday, 13 February 2020

8160	Open	DCS	Policy Review Committee
<i>Item No</i>	10.6	That Council defer the adoption of new policy CS4.6 Welcome to Country; and refer this item back to the Policy Review Committee for further consideration.	
<i>Date Moved</i>	18-Jun-19		
<i>Date Completed</i>			
<i>Comment</i>	In progress.		

8169	Open	DDS	115 Throssell Street, Collie (Golden Eagle Restaurant) Incentive Grant
<i>Item No</i>	13.2	That Council:	
<i>Date Moved</i>	18-Jun-19	1)reconstructs a balcony and verandah at 115 Throssell Street, Collie in general accordance with the original structure;	
<i>Date Completed</i>		2)in accordance with policy DS4.4, allocate an amount of up to \$10,000 excluding GST from the Shire of Collie Heritage Incentive Scheme from the 2019-2020 budget to this project on a 50/50 basis;	
		3)waive all Council fees; and	
		4)authorise the Chief Executive Officer to enter into agreements with current and previous owners of 115 Throssell Street, Collie.	
<i>Comment</i>	Construction commenced 23/01/2020. Anticipated completion 17/03/2020		

8224	Open	CEO	Adopt the Recommendations of the Minutes of the Economic Development Advisory Committee
<i>Item No</i>	10.4	That Council;	
<i>Date Moved</i>	20-Aug-19	10.4.1 defer the Collie Futures Fund Grant Application – Trails and Trail Town so that staff can provide more details.	
<i>Date Completed</i>		10.4.2	
		1. Purchase a 12-month basic subscription for Spendmapp for the Economic Development Fund up to \$10,000;	
		2. Seek a contribution towards the subscription from other organisations if possible;	
		3. Review the effectiveness of the software at the end of the 12-month period.	
<i>Comment</i>			

Motion Report - Show All Open Motions

(Sorted by Officer, Motion No.)

Thursday, 13 February 2020

8238 **Open** **DTS** **Adopt the Recommendations of the Townscape Advisory Committee**

Item No 10.2 That Council request staff investigate the timetable and frequency of tourist buses that pull into the Railway Building and report back to the Townscape Advisory Committee.

Date Moved 10-Sep-19

Date Completed

Comment Awaiting response from staff at Railway Building

8255 **Open** **DTS** **Motions for which prior notice has been given.**

Item No 15 That the Collie Shire Council write to Main Roads requesting that the 80km/hr speed limit through Allanson be extended West to the other side of Rose Road.

Date Moved 01-Oct-19

Date Completed

Comment Follow up email sent 14 November 2019. Awaiting reply from Main Roads

Motion Report - Show All Open Motions

(Sorted by Officer, Motion No.)

Thursday, 13 February 2020

8270	Open	SPO	Draft Local Planning Scheme No. 6
<i>Item No</i>	13.2		That Council:
<i>Date Moved</i>	01-Oct-19		1.Resolve to proceed to advertise the draft Local Planning Scheme No. 6 with modification pursuant to Regulation 21(1) of the Planning and Development (Local Planning Schemes) Regulations 2015. The modification is Page 14 zoning table –
<i>Date Completed</i>			a) Resource Recovery Centre is changed from an A use to an I use in the Rural Zone. b) Brewery changed from an X use to an I use in the Rural Residential Zone.
			2.Refer the draft Local Planning Scheme No. 6 to the Environmental Protection Authority under Section 81 of the Planning and Development Act 2005;
			3.Submit two (2) copies of the draft local planning scheme documents to the Western Australian Planning Commission for its examination under section 21(2) of the Planning and Development (Local Planning Schemes) Regulations 2015;
			4.Refer the draft Local Planning Scheme No. 6 to the Heritage Council;
			5.Subject to formal assessment not being required by the Environmental Protection Authority and subject to the Western Australian Planning Commission granting consent to advertise, advertise the draft Local Planning Scheme No. 6 pursuant to Regulation 22(1-4) of the Planning and Development (Local Planning Schemes) Regulations 2015; and
			6.Delegates authority to the Chief Executive Officer to determine whether any material changes, required by the WAPC/EPA or any other changes to the draft Local Planning Scheme No. 6 should be referred to Council prior to advertising.
<i>Comment</i>	Draft Scheme has been referred to the EPA, Heritage Council and WAPC. Formal assessment not required by the EPA. Awaiting response form WAPC.		

Motion Report - Show All Open Motions

(Sorted by Officer, Motion No.)

Thursday, 13 February 2020

8271	Open	SP	Activities in Thoroughfares and Public Places and Trading Local Law 2019
<i>Item No</i>	13.3		That Council by ABSOLUTE MAJORITY;
<i>Date Moved</i>	01-Oct-19		1.Under Clause 2.8 add a sub point e) other verge treatments at the discretion of Council;
<i>Date Completed</i>	01-Jan-20		2.Advertises its intention to make a new Activities in Thoroughfares and Public Places and Trading Local Law 2019 as per Appendix 5 and forwards a copy of the proposed Shire of Collie Activities in Thoroughfares and Public Places and Trading Local Law 2019 to the Department of Local Government, Sport and Cultural Industries for the Minister's consideration;
			3.Notes the purpose of the proposed Shire of Collie Activities in Thoroughfares and Public Places and Trading Local Law 2012 is to provide for the orderly management of the Shire's thoroughfares and public places;
			4.Notes the effect of the proposed Shire of Collie Activities in Thoroughfares and Public Places and Trading Local Law 2012 is to advise that some activities are prohibited and some activities are permitted only under permit on thoroughfares and public places within the Shire of Collie.
			That staff conduct a review of local governments that do not currently have an Activities in Thoroughfares and Public Places and Trading Local Law in place with a view to understanding how they manage risks and report back to Council prior to the adoption of this local law.
<i>Comment</i>	Research underway 11/10/19		

Motion Report - Show All Open Motions

(Sorted by Officer, Motion No.)

Thursday, 13 February 2020

8298	Open	DDS	Recommendations of the Minutes of the Weeds and Waterways Advisory Committee
<i>Item No</i>	10.4		That Council adopts en bloc the recommendations contained within the minutes of the Weeds and Waterways Advisory Committee held on 10 October 2019.
<i>Date Moved</i>	22-Oct-19		That Council;
<i>Date Completed</i>			10.4.11. supports the formation of a Recognised Biosecurity Group in accordance with the requirements of the Biosecurity and Agriculture Management Act 2007;
			2. enquire if all surrounding Shires are interested in the establishment of the recognized Biosecurity Group with the Shire of Collie and if they have similar priorities with regards to declared pests;
			3. advertise for the establishment members of the Recognised Biosecurity Group.
			4. in conjunction with the Department of Primary Industries and Regional Development, assist the Recognised Biosecurity Group to become incorporated and to form an Objective;
			5. investigate opportunities for cooperation and an MOU between the Recognised Biosecurity Group and the Shire of Collie; and
			6. request the Department of Primary Industries and Regional Development provide establishment funding for the Recognised Biosecurity Group.
			10.4.2write to the Weeds and Waterways Advisory Committee members and guests thanking them for attending meetings and their input over the many years.
<i>Comment</i>	Actions ongoing		
8301	Open	DTS	Notice of Motion by Cr Miffing
<i>Item No</i>	15		1.That Council's engineering department be requested to investigate and report to Council on a redevelopment plan for the portion of Johnston Street between Harvey to Lefroy Streets inclusive of the roadway, adjacent footpaths and entry/exit points to the various parking areas.
<i>Date Moved</i>	22-Oct-19		2.Council to consider allocating an amount of \$10,000 in the mid-year budget review for design and street scape plans.
<i>Date Completed</i>			
<i>Comment</i>	Awaiting the mid year budget review before proceeding with designworks		

Motion Report - Show All Open Motions

(Sorted by Officer, Motion No.)

Thursday, 13 February 2020

8336	Open	CEO	Minninup Pool Tourism Project Update
<i>Item No</i>	11.1		That Council;
<i>Date Moved</i>	10-Dec-19		1. Notes the progress of the Minninup Pool tourism project
<i>Date Completed</i>			2. Receives the Minninup Pool Demand and Prefeasibility Study undertaken by Brighthouse;
			3. Supports the campground and day use areas of the project proceeding to detail design and development of indicative costings;
			4. Supports the eco accommodation concept area of the project and progressing sufficient design works to determine head work costs.
			5. Supports the Minninup Pool Project Management Group undertaking discussions with the commercial sector to gauge interest in developing and operating the campground, eco accommodations and the area known as Kings Park as per the concept plans.
			6. Apply to the Minister of Lands to vary the vesting of Reserve 23606, R34343 to include accommodation, tourist uses and power to lease for up to 99 years.
<i>Comment</i>			
8337	Open	CEO	Bunbury Geographe Tourism Partnership (BGTP) - Memorandum of Understanding (MOU) extension.
<i>Item No</i>	11.2		That Council;
<i>Date Moved</i>	10-Dec-19		1. endorses an extension of the Bunbury Geographe Tourism Partnership (BGTP) Memorandum of Understanding from 12 December 2019 to 30 June 2020.
<i>Date Completed</i>			2. That subject to item 1, Council notes:
			a. the extension is to allow the completion of a review of the MOU and consideration by all member local governments of their continuing involvement and investment into BGTP by March 2020.
			b. the outcomes of the March 2020 MOU review will be presented to each Council for consideration and confirmation on their position on the BGTP involvement post 30 June 2020.
			c. the financial provision of 30% of the City's (Shire's) annual contribution by invoice from the City of Bunbury, to enable the ongoing engagement of the Tourism Marketing and Development Manager for the extended period of the MOU.
<i>Comment</i>			CEO's Meeting 10 February 2020 to progress.

Motion Report - Show All Open Motions

(Sorted by Officer, Motion No.)

Thursday, 13 February 2020

8344	Open	DTS	Notice of Motion (2) by Cr Faries - Jarrah Log
<i>Item No</i>	15		Council investigate the costs to put down foundations to place the log pictured at the timber park to enhance the parks Jarrah display.
<i>Date Moved</i>	10-Dec-19		
<i>Date Completed</i>			
<i>Comment</i>			

8356	Open	DTS	Disposal of Minor Plant Items
<i>Item No</i>	14.1		That Council: Dispose of the following items of minor plant items via an on-line public auction without a reserve price:-
<i>Date Moved</i>	28-Jan-20		- Minor plant trailer
<i>Date Completed</i>			- 1 set of ramps
			- Truck mounted Fassi Hiab
			- Grader blade attachment for Skidsteer loader
			- Stump grinder attachment for Skidsteer loader
			- Sweeper attachment for Skidsteer loader
			- Unused Ram
<i>Comment</i>			

8357	Open	DTS	2019/20 Plant Replacement Program
<i>Item No</i>	14.2		That Council allocate \$107,000 (ex GST) from Plant Reserve account towards the following purchases;
<i>Date Moved</i>	28-Jan-20		1 Purchase of a new skid steer loader including 4-in-1 bucket to the value of \$80,000 (ex GST) for the works crew. The new machine is to be compatible with the rake bucket, auger, profiler and fork attachments currently owned by Council. Disposal of the current Bobcat skid steer loader is to be either via public auction or trade-in, whichever is best value to Council.
<i>Date Completed</i>			2 Purchase of a new commercial grade ride on mower with catcher to the value to \$27,000 (ex GST) suitable for mowing Central Park.
<i>Comment</i>			

Motion Report - Show All Open Motions

(Sorted by Officer, Motion No.)

Thursday, 13 February 2020

8358	Open	DTS	Collie Mural Project
<i>Item No</i>	17		That Council nominate Cr Scoffern with Cr Woods as proxy as the Council's nominee(s) for the Collie Mural Project.
<i>Date Moved</i>	28-Jan-20		
<i>Date Completed</i>			
<i>Comment</i>			
